



USE AND MAINTENANCE INSTRUCTIONS

**PELLET FIREPLACE
INSERT**

Eolo Air

Zefiro Air

Read instructions carefully before installation, use and maintenance
The instruction manual is an integral part of the product

Laminox S.r.l. reserves the right to change the characteristics and data reported in the following document at any time and without warning in order to improve their products. This manual, therefore, cannot be considered as a contract with third parties.

The updated manuals and drawings are available on the website www.laminox.com.

Dear Customer, thank you for choosing one of our products, which is a result of technological expertise and our continuous quest for superior products in terms of safety, reliability and performance. This manual contains all the information and helpful tips for using your product with maximum safety and efficiency.

IMPORTANT INFORMATION

This manual has been prepared by the manufacturer and is an integral and essential part of the product. In the event of sale or transfer of the product, always ensure the presence of the manual as the information it contains is addressed to the buyer and to all those various people involved in the installation, use and maintenance of the product. Carefully read the instructions and information contained in this manual before installation, operation and maintenance of the product. The instructions contained in this instruction manual guarantee the safety of persons and property and ensure efficient operation and a longer service life. The manufacturer declines all responsibility for damage caused by failure to observe instructions regarding installation, use and maintenance listed in the instruction manual, for unauthorized modifications or non-original replacement parts. Product installation and use must be carried out in accordance with the manufacturer's instructions and in compliance with European, national and local regulations. Installation, electrical connection, functional testing, maintenance and repairs are operations that must be performed by qualified and licensed personnel who must have appropriate knowledge of the product. Product installation must not be carried out close to walls made of wood or combustible material. For proper installation, you must observe the "Safety distances" section. Verify the exact flatness of the floor where you will install the product. When handling the steel parts of the cladding, use clean cotton gloves to prevent leaving fingerprints difficult to remove for the first cleaning. Fireplace installation must be performed by at least two people. Connect the fireplace to the mains only after proper professional connection to the chimney flue. The power cable plug must remain accessible after installation of the fireplace. Only operate the fireplace with regulation wood pellets (refer to the "FUEL" chapter). Never use liquid fuels to operate the pellet fireplace or to stoke the embers present. Provide adequate ventilation in the installation area during operation. In the presence of operation failures, fuel supply will be interrupted. Re-start the unit after removing the cause of the failure. Discontinue use of the product in the event of failure or malfunction. Do not remove the safety guard located in the pellet tank. Any accumulated unburned pellets in the burner as a result of repeated failed ignitions must be removed prior to ignition. Pellet fireplace operation can cause very hot heating of the handles, the chimney flue and glass surfaces. Only touch these parts during operation when wearing protective clothing or with adequate aids. Because of the creation of heat on the glass, make sure that no persons unfamiliar with fireplace operation stand in the installation area. Inform children of the precautions to be observed during product operation and of possible dangers. In the event of problems or misunderstanding of the instruction manual, contact the dealer. Placing objects which cannot withstand heat on the fireplace or within the minimum required safety range is prohibited. Do not open the door during operation or operate the fireplace with its glass broken. For product terms, limitations and exclusions, please refer to the warranty included with the product. In order to pursue a policy of constant product development and renewal, the manufacturer may make changes to it as deems appropriate without notice. This document is the property of the manufacturer and cannot be disclosed in whole or in part to any third party without the written consent of the company, which reserves all rights according to the law.

DIRECTIVES AND REGULATIONS

This product has been designed in accordance with the EN 14785:2006 standard and also complies with the following directives:

2009/125/EC (Ecodesign)

2014/35/EU (LVD – Low Voltage directive)

2014 30/EU (EMC – Electromagnetic Compatibility)

2014/53/UE (RED – Radio Equipment Directive)

2011/65/EU (ROHS)

1	INSTALLATION.....	4
1.1	General notes.....	4
1.2	Smoke discharge system	4
1.3	Smoke duct	5
1.4	Chimney of flue	5
1.5	Using an external fume duct.....	7
1.6	Chimney pot.....	7
1.7	External air intake vent.....	8
1.8	Installation room.....	10
1.9	Minimum safety distances	11
1.10	Passing through combustible materials	12
2	SPECIFICATIONS AND TECHNICAL DATA.....	13
2.1	Specifications	13
2.2	Technical data.....	13
2.3	Product identification data	13
2.4	Electrical diagrams.....	13
3	FUEL	15
3.1	General notes.....	15
4	ASSEMBLY	16
4.1	General notes.....	16
4.2	Unpacking	16
4.3	Installation and assembly	16
4.4	Electrical connection	17
4.5	Fume duct connection	18
4.6	Primary air.....	18
4.7	External thermostat installation	19
5	USE	20
5.1	Remote control description.....	21
5.2	First ignition.....	22
5.3	Pellet load	22
5.4	Ignition and normal operation	23
6	MENU	26
6.1	Menu 01 "FANS ADJUSTMENT".....	26
6.2	Menu 02 "CLOCK SET".....	26
6.3	Menu 03 "CHRONO SET"	26
6.4	Menu 04 "CHOOSE LANGUAGE"	29
6.5	Menu 05 "CHOOSE PROBE"	30
6.6	Menu 06 "STAND-BY MODE"	30
6.7	Menu 07 "BUZZER MODE"	30
6.8	Menu 08 "INITIAL LOAD"	30
6.9	Menu 09 "FIREPLACE STATUS"	30
6.10	Menu 10 "TECHNICAL CALIBRATION"	31
6.11	Menu 11 "PELLET TYPE"	31
6.12	Menu 12 "FIREPLACE TYPE"	31
7	SAFETY AND ALARMS.....	32
7.1	Safety devices.....	32
7.2	Alarms.....	33
8	WARNING AND MAINTENANCE	35
8.1	Opening the door	35
8.2	Ash drawer cleaning.....	35
8.3	Brazier cleaning	35
8.4	Combustion chamber cleaning	36
8.5	Smoke chamber cleaning	36
8.6	Exhaust system cleaning.....	36
8.7	Cleaning metal and ceramic parts	36
8.8	Cleaning glass.....	36
8.9	Broken glass	36
8.10	Replacing the remote-control battery.....	37
8.11	Cleaning fans	37
8.12	Fireplace inactivity.....	37
8.13	Routine and special maintenance.....	37

1 INSTALLATION

1.1 General notes

The heating system or appliance must be installed in order not to damage the building and other systems. The installer must strictly comply with standard UNI 10683:2022 and all other applicable local regulations.

1.2 Smoke discharge system

Every device must be connected to a fume discharge system, which ensures dispersion of combustion products into the atmosphere.

The fume discharge system must meet the following requirements:

- The combustion products must be discharged from the roofs. Direct wall discharge or towards closed spaces, even in open air, is prohibited.
- The components must be made of material with A1 fire reaction class. In particular, the use of metal extendible and flexible hoses is prohibited.
- It must be ensured that the duct is completely sealed and correctly installed
- Tubes must **ALWAYS** be sealed with silicone (**no cementing**) that maintains resistance and elasticity characteristics at high temperature (250°C) and are to be secured with a Ø3.9mm self-tapping screw.
- Construction of the exhaust duct must be done by specialised personnel or companies, as reported in the following manual. Always create the exhaust system so that periodic cleaning is assured without having to dismantle any parts.
- The installation of dampers or valves which may obstruct the passage of exhaust fumes is **prohibited**.
- Installation in a chimney flue where exhausted fumes or vapours from other equipment (boilers, hoods, etc.) is **prohibited**.
- It should not be connected to any other fireplace, fireplace, boiler, or hood of any kind (*Fig. 1*).

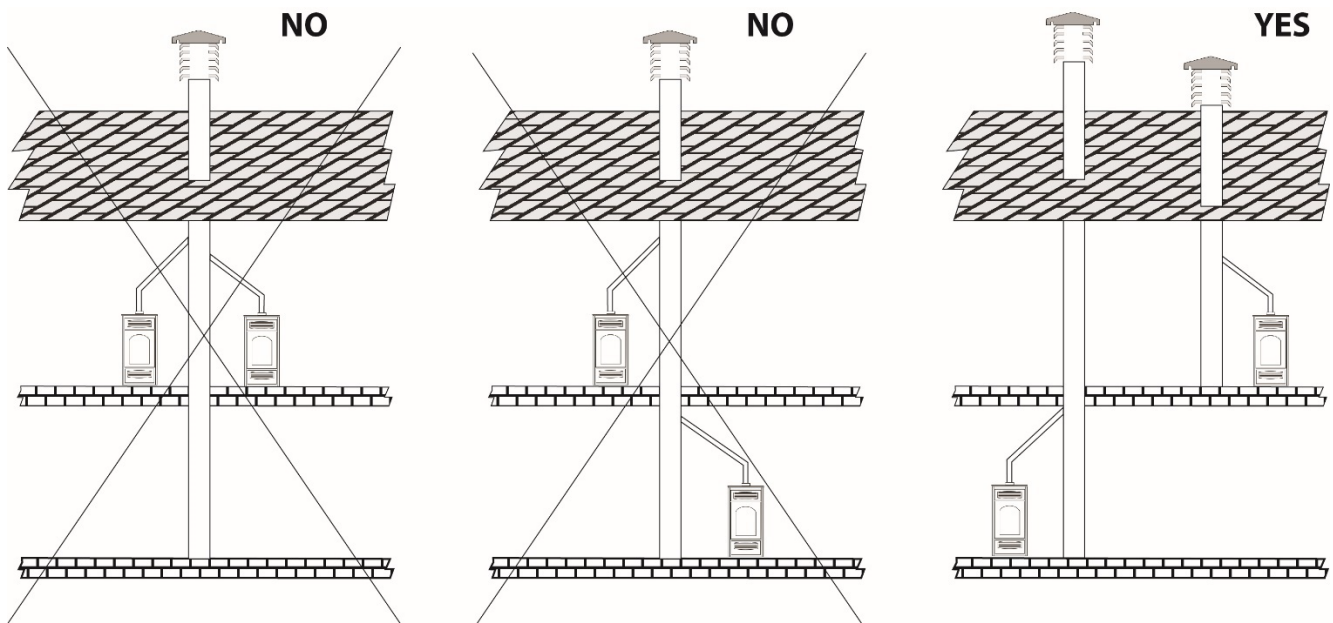

Fig.1

1.3 Smoke duct

The smoke duct is the pipe that connects the appliance to the Chimney

The smoke ducts must be installed in compliance with the following general requirements:

- If they pass inside unheated rooms or outside, they must always be insulated so as to have thermal resistance R not less than 0.12 m²K/W.
- They must not pass through rooms in which the installation of combustion appliances is forbidden
- They must not pass through rooms at risk of fire or rooms that cannot be inspected
- They must be installed in such a way as to allow for normal thermal expansion
- Along their entire length, they must have a diameter no less than that of the attachment of the appliance's evacuation duct
- They must allow the recovery of soot and be inspectable
- They must be equipped with an element with a sampling hole in accordance with UNI 10389-2
- The use of flexible metal pipes to connect the appliance to the chimney is not permitted

1.4 Chimney of flue

Each appliance must have its own flue with the following characteristics:

- Must have a section equal to or greater than the diameter of the fume exhaust pipe of the fireplace and a height no less than the one stated (*see table 1*)
- Must operate in negative pressure
- The internal section must be uniform, preferably circular: the square or rectangular sections must have rounded corners with a radius of no less than 20 mm, maximum ratio between the sides of 1.5, walls as smooth as possible and without restrictions, curves must be regular and seamless, deviations from the axis no greater than 45° (*Fig. 2*).
- It must not have more than two changes of direction with slopes not exceeding 45°
- It must be used exclusively for the evacuation of combustion products
- It must have a mainly vertical course and be free from any bottleneck along their entire length
- It must have a draft that complies with the indications in the product's **technical data sheet**
- It must be properly spaced from combustible or flammable materials through an air gap or suitable insulating material.
- Creating fixed or mobile apertures on the chimney flue to connect equipment other than auxiliary devices is prohibited.
- Passing other air supply channels and piping for utilities through the chimney flue, however large, is prohibited.
- The chimney flue should be equipped with a collection chamber for solid materials and any condensate, located below the mouth of the flue, so as to be easily opened and inspected from an airtight door.
- Whenever using parallel output chimneys, it is advisable to raise a bracing element. (*Fig.6*)

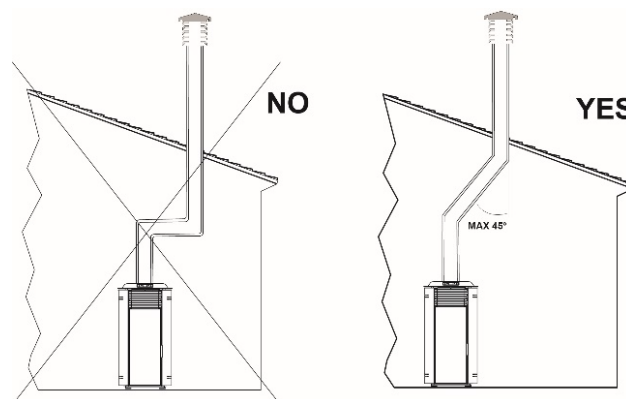

Fig.2

1.4.1 Maximum usable lengths

Painted aluminised steel tubes (minimum thickness 1.5 mm), stainless steel tubes (Aisi 316) or porcelain tubes (minimum thickness 0.5 mm) with a nominal diameter of **80 mm** or **100 mm** (for tubes inside the chimney flue max 150 mm) can be used.

Flexible hoses are permitted if they fall within the limits prescribed by law (in stainless steel with smooth inner wall). The male-female connection collars must be at least 50 mm long.

Tube diameter depends on the type of system. The fireplace has been designed for Ø 80 mm and Ø 100 mm tubes (check the technical data sheet of the selected model). As can be seen in the table below, a double-wall Ø 100 mm tube may be necessary in some cases and models.

TYPE OF SYSTEM	WITH Ø 80 mm TUBE	WITH DOUBLE-WALL Ø 100 mm TUBE
Minimum length	1.5 m	2m
Maximum length (with 3 90° curves)	4.5 m	8m
For installations situated over 1200 m above sea level	-	mandatory
Maximum number of curves	3	4
Horizontal sections with min. 5% incline	2m	2m

Tab.1

NOTE: load losses of a 90° curve can be equated with those of 1 metre of tube; the serviceable T-connection is to be considered as a 90° curve.

1.4.2 Using an existing chimney flue

If you wish to use an already existing chimney flue, it is advisable to have it checked by a professional chimney sweep to ensure that it is watertight. This is because fumes, being slightly pressurised, could infiltrate cracks in the chimney flue and invade living spaces. If an inspection finds that the chimney flue is not perfectly intact, it is advisable to intubate it with new material. If the existing chimney is large, we recommend inserting a tube with a maximum diameter of 150 mm. It is also advisable to insulate the fume exhaust duct. Figs. 3 and 44 demonstrate the solutions to adopt if you want to use an existing chimney flue.

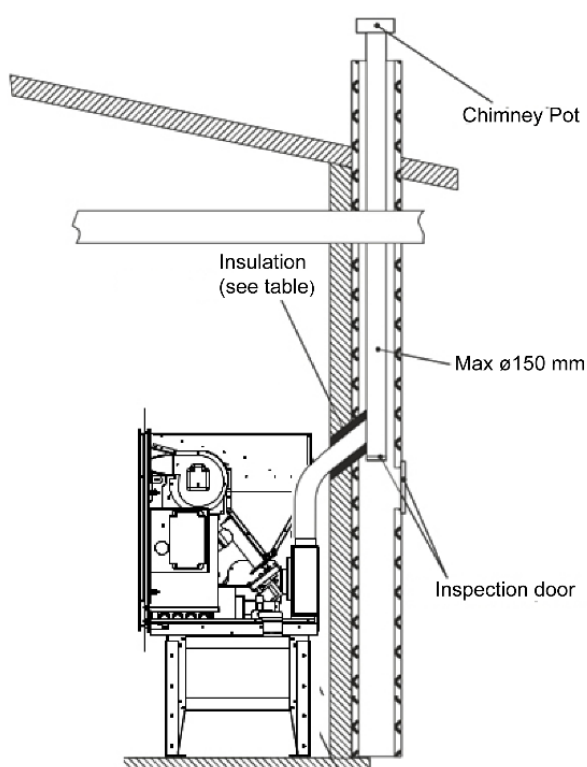

Fig. 3

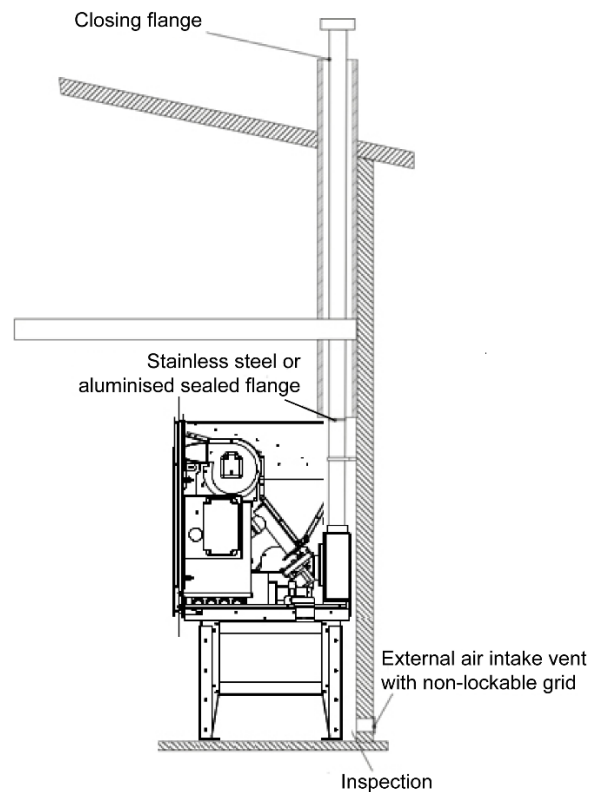

Fig. 4

1.5 Using an external fume duct

An external fume duct can be used only if it meets the following requirements:

- Only insulated tubes (**double wall**) in stainless steel, secured to the building (*Fig.5*) should be used.
- An inspection area should be created at the base of the duct for performing periodic checks and maintenance.
- It should be equipped with a windproof chimney pot and observe the distance "d" from the ridge of the building as described in par. 1.6.

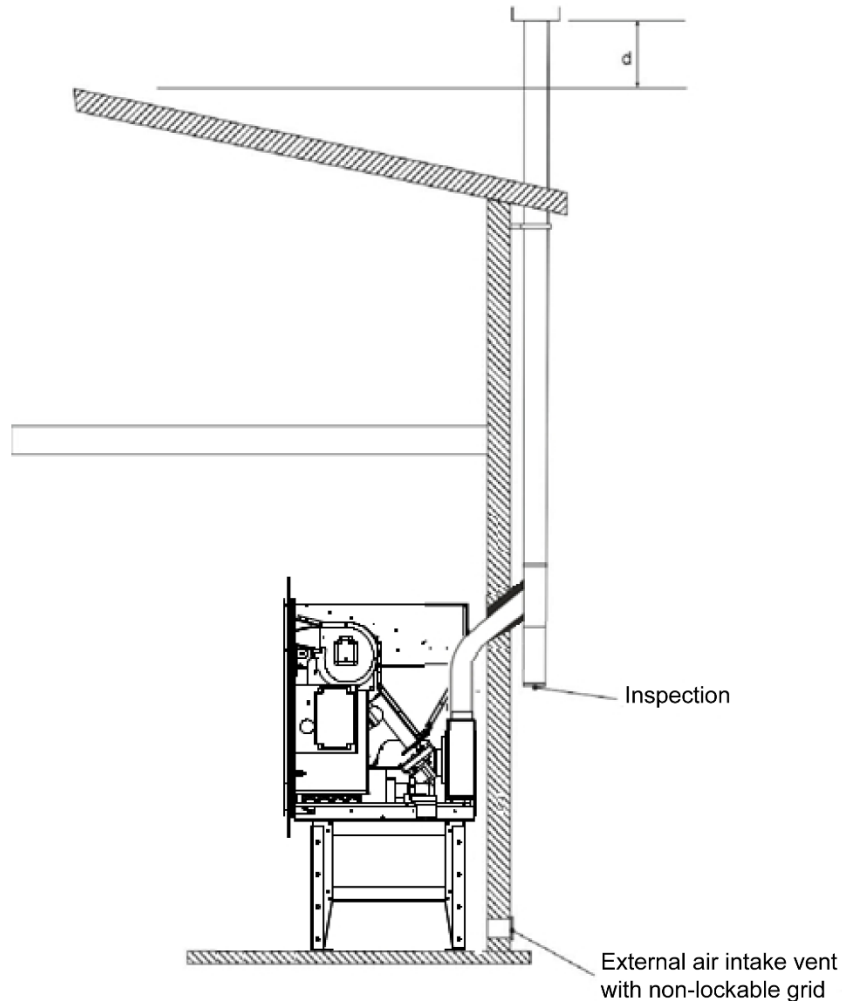

Fig. 5

1.6 Chimney pot

The top of the chimney flue must be equipped with a device, called a chimney pot, which facilitates dispersion into the atmosphere of combustion products.

The chimney pot must meet the following requirements:

- Its internal section and shape must be equivalent to that of the chimney flue.
- Have a useful outlet section no less than double that of the chimney flue.
- Chimney pots that emerge from the roof or which remain in contact with the outside (for example in the case of an open loft), must be covered with brick elements and well isolated. It must be constructed so as to prevent penetration into the flue of rain, snow, or foreign bodies and so that, in the event of winds in any direction and at any angle, it assures the discharge of combustion products (windproof chimney pot).
- The chimney pot must be positioned so as to guarantee an adequate dispersion and dilution of combustion products and, in any case, outside the zone of reflux. This zone can be different sizes and shapes depending on the angle of slope of the roof, so it is necessary to adopt the minimum heights shown in *Fig.7* and *Fig.8*.
- The chimney pot must be of windproof and exceed the height of the ridge, (*Fig.7* and *Fig.8*).
- Any buildings or other obstacles that exceed the height of the chimney pot must not be close to the chimney pot itself (*Fig.7*).

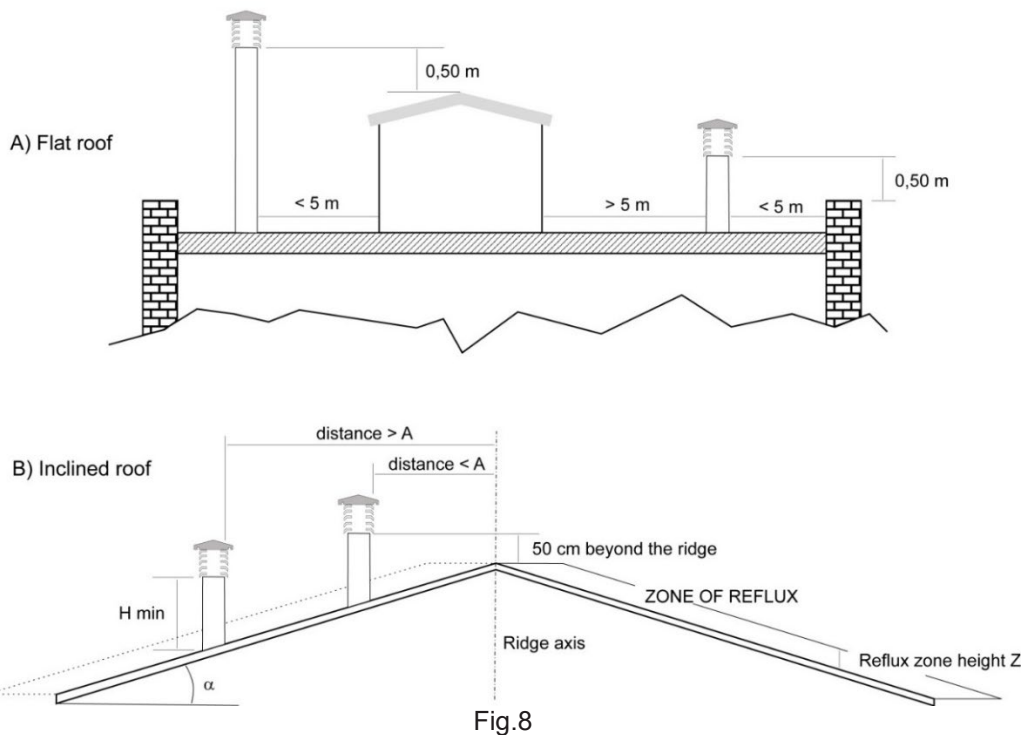
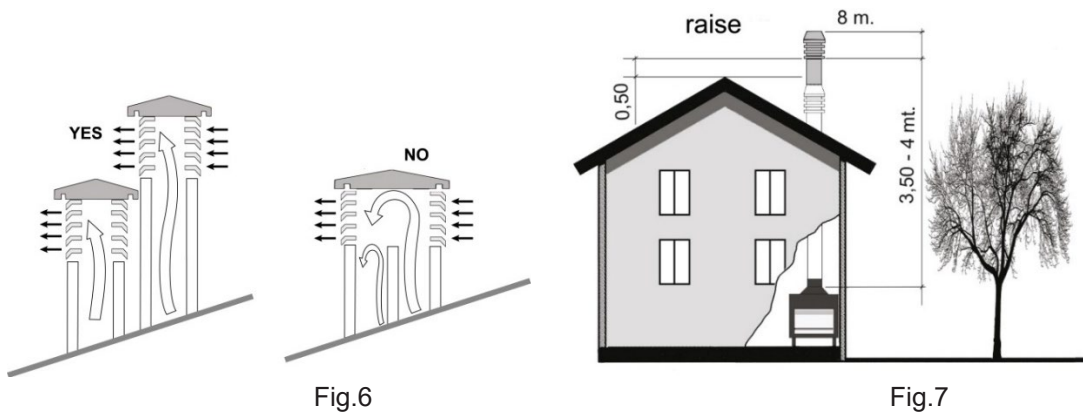

1.7 External air intake vent

The fireplace must have the air necessary to ensure smooth combustion operation and good environmental well-being.

Make sure that the room where the fireplace is installed offers sufficient ventilation and install an air supply duct from the outside with the recommended minimum section of **100 cm²**.

Ventilation openings are not required:

- In the case of an airtight installation
- If the room has permanent permeability to external air which ensures that under any conditions a depression greater than -4 Pa does not occur

Ventilation opening:

- They must be positioned close to the floor
- They must be made so as to make maintenance operations possible
- They must be protected by grids, metallic nets, etc., without reducing their net useful section

In the case of a closable vent, this must be:

- Normally open
- Open automatically when the appliance is turned on

1.7.1 Direct Vent

Direct ventilation must be achieved via ventilation openings directly in the installation room of the appliances

1.7.2 Indirect vent

Air flow can also be obtained from a room adjacent to the installation room, provided that this flow can be carried out freely through permanent, non-closable openings communicating with the outside.

In case of passage through several rooms, the net section of the ventilation opening must be doubled at each passage

With respect to the installation room, the adjacent room should not be put under vacuum with respect to the external environment as a result of a reverse draft caused by the presence in this space of another utility device or suction device. The room adjacent to the permanent openings must meet the requirements set out in the paragraphs above. The adjacent room cannot be used as a garage, for storage of combustible material or for activities involving a risk of fire

1.7.3 Minimum convective air sections

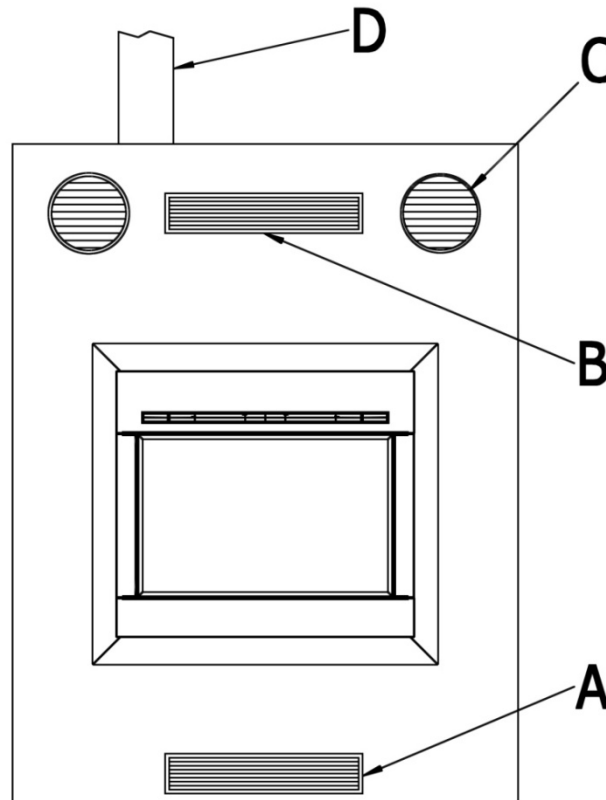

Fig.9

Convective air inlet/outlet sections:

Minimum input section convective air:	A = 500 cm ² ;
Minimum output section convective air:	B = 500 cm ²
Minimum output section convective air:	C = 0
Test fireplace inner diameter:	D = 100 mm

1.7.4 Hood ventilation grids

The product can be used in two different ways:

- as insertion on an existing cladding,
- as new installation.

If it is inserted on an existing cladding, the ventilation grids on the cladding will be used.

If it is used as a new installation, the manufacturer recommends installing ventilation grids (convective air) of at least 500 cm², one of delivery into the environment and one of suction from the environment, which can be arranged according to the positions A or B (also see par. 1.6.1).

The company is not responsible for any damage to the structure or electrical components caused by failure to observe this warning.

The structure reaches high temperatures and it is essential to always ensure continuous and efficient ventilation inside the cladding.

This procedure, as well as guarantee a perfect operation of the product, allows to recover part of the heat of the structure which would be lost if it remained inside the cladding.

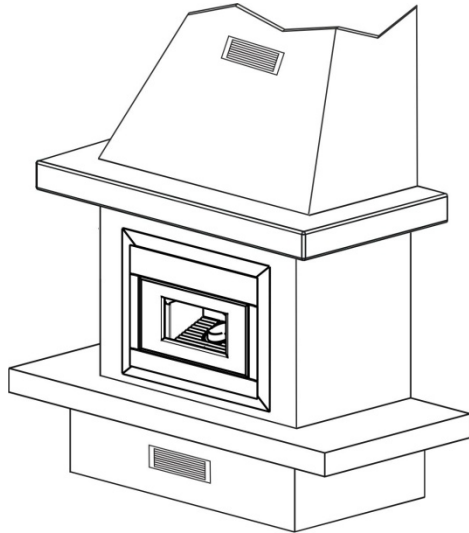

Fig.10

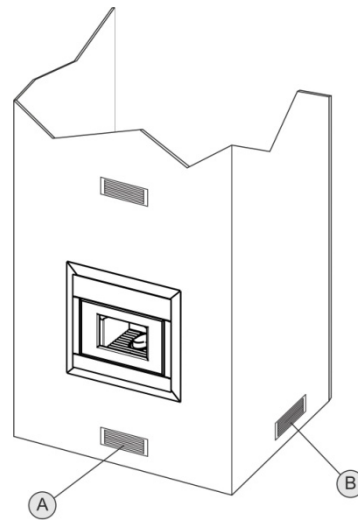

Fig.11

1.8 Installation room

- Installing the device inside rooms at risk of fire is prohibited.
- **Outdoor installation** in locations exported to weathering or humid areas **is prohibited**.
- In bathrooms, bedrooms and studios can be installed only airtight appliances with external ducted combustion air intake.
- Fireplace installation must be carried out in a location which allows safe and easy use and simple maintenance. Said location must also be equipped with electrical grounding as required by law.

1.8.1 Preventing house fires

- The installation room must not be at risk of fire or used as a warehouse for combustible material. The storage of solid fuel for a maximum volume of 1.5 m³ is permitted in the room where the appliance is installed
- The fireplace connecting tube must never pass through a combustible surface
- It is also advisable to maintain all combustible elements or flammable material such as beams, wooden furniture, curtains, flammable liquids, etc. outside the radiation area of the furnace and at a distance of at least 1 m from the heating block.
- In the event that the surrounding space has coverings in combustible or heat-sensitive material, a protective membrane made of non-combustible insulating material must be interposed. If the flooring is made of combustible material, a non-combustible protective material that protrudes laterally and frontally from 15 cm to 30 cm must be provided at the mouth of the furnace.

For further information, refer to local requirements.

CAUTION: when a fume exhaust pipe passes through a wall or ceiling, particular installation methods must be applied (protection, thermal insulation, distances from heat sensitive materials, etc.).

CAUTION: Appliances installed in the same room or in adjacent and communicating rooms must be considered, for the purpose of fire prevention, as forming part of a single system, with a thermal power equal to the sum of the powers of the single appliances.)

1.8.3 Installation in presence of several appliances

The following table shows the possible installation configurations of several appliances in the same room or in adjoining rooms

	Biomass appliance with non-airtight installation	Biomass appliance with airtight installation	Type A Gas appliance	Type B Gas appliance	Type C Gas appliance	Gas cooking appliances
Biomass appliance with non-airtight installation	Admitted in compliance with UNI 10683	Allowed	Forbidden	Forbidden	Allowed	Allowed
Biomass appliance with airtight installation*	Allowed	Allowed	Allowed	Allowed	Allowed	Allowed

Tab.2

* An airtight installation does not consume the oxygen of the room by taking all the air from outside (if suitably ducted) and allows the product to be installed inside all houses that require a high degree of insulation such as “passive houses”. Thanks to this technology there is no risk of smoke emissions into the room and there is no need for air intakes in the installation room.

1.8.4 Minimum volume of the installation room

To calculate the minimum volume of the installation room, the formula

Room Volume = 10 x Appliance Power must be used

Room Volume is expressed in m³ and Appliance Power is expressed in kW and is equal to the minimum power of the machine

1.8.5 Capacity of the floors of the installation room

The floor of the installation room must have a capacity suitable for supporting the total weight of the appliance

1.9 Minimum safety distances

The following figures show the minimum safety distances which must always be guaranteed.

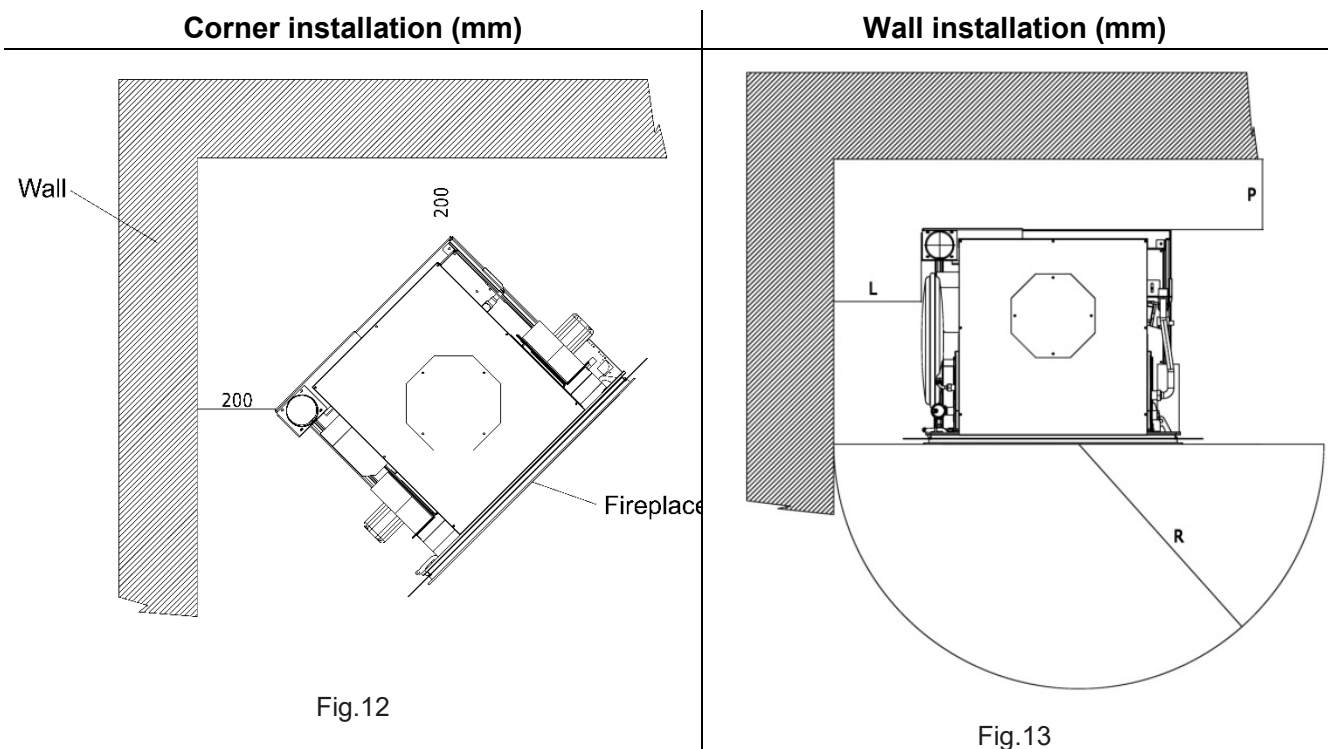

Safety distances from flammable material

Minimum distance in air from the flammable rear wall

Minimum distance in air from the flammable side wall

Frontal distance from flammable material

P = 280 mm

L = 380 mm

R = 1000 mm

Installation distances from flammable material

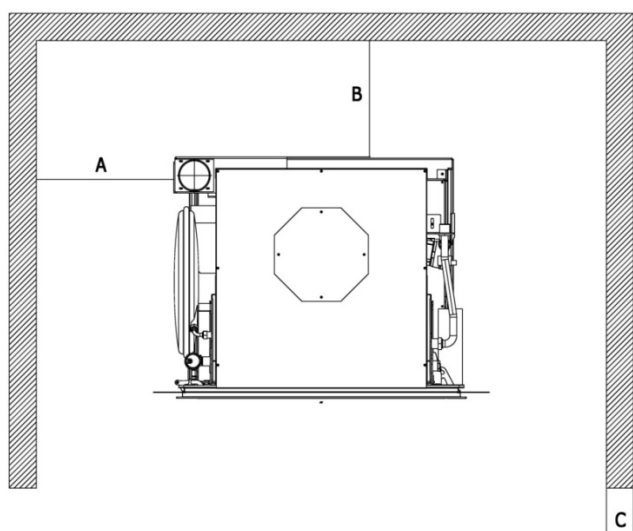

Fig. 14

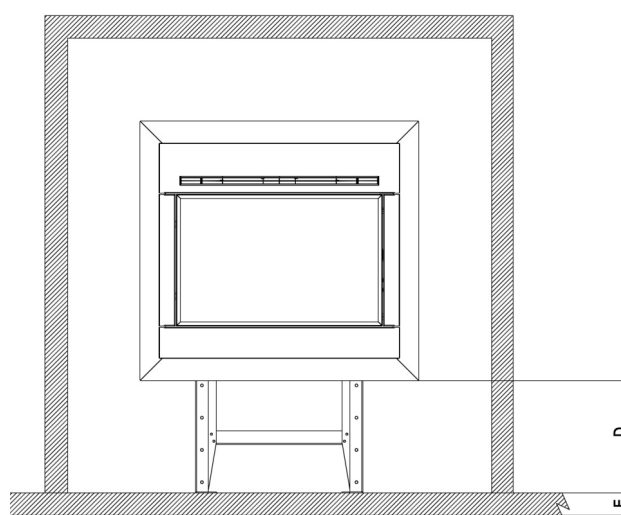

Fig. 15

- Distance in air from the side wall: *A = 300 mm;*
- Distance in air from the rear wall: *B = 250 mm;*
- Thickness of the insulating material side/rear wall: *C = 80 mm;*
- Distance in air from the floor: *D = 200 mm;*
- Thickness of the insulating floor material : *E = 0 mm;*
- Minimum front distance in air from flammable material : *100 cm.*

Specifications of the insulating material

Light Calcium Silicate insulation plates for High Temperature

Classification temperature	°C	1000
Density	<i>kg/m³</i>	245
Reference temperature shrinkage, 12 hours	%	<i>1.3/1000 °C</i>
Resistance to cold compression	<i>MPa</i>	1,4
Resistance to bending	<i>MPa</i>	0,5
Coefficient of thermal expansion	<i>m/mK</i>	<i>5,4x10⁻⁶</i>
Specific heat	<i>Kj/kgK</i>	1,03

1.10 Passing through combustible materials

Once the location of the fireplace has been decided, you will have to drill the hole for passage of the fume exhaust tube. This varies depending on the type of installation (therefore on the exhaust tube diameter) and on the type of wall or roof to be crossed (table 3).

The insulator must be of mineral origin (rock wool, ceramic fibre) with a nominal density greater than 80 kg/m³.

	Insulation thickness [mm]	Fume exhaust tube diameter [mm]	
		Ø80	Ø 100
		Diameter of holes to be created [mm]	
Wooden wall, or wall which is flammable or has flammable parts	100	280	300
Concrete wall or roof	50	180	200
Brick wall or roof	30	140	160

Tab.3

2 SPECIFICATIONS AND TECHNICAL DATA

2.1 Specifications

Pellet fireplaces are devices built to work with good quality wood pellets only (see par. 3 fuel).

2.2 Technical data

The technical data of the individual models can be found on the website www.laminox.com

2.3 Product identification data

The technical label shows device data and performance. Tampering with, removing or lack of a technical label makes installation and maintenance operations difficult, due to the lack of product identification. In the event of damage, request a duplicate from our service centre.

2.4 Electrical diagrams

2.4.1 Zefiro Air

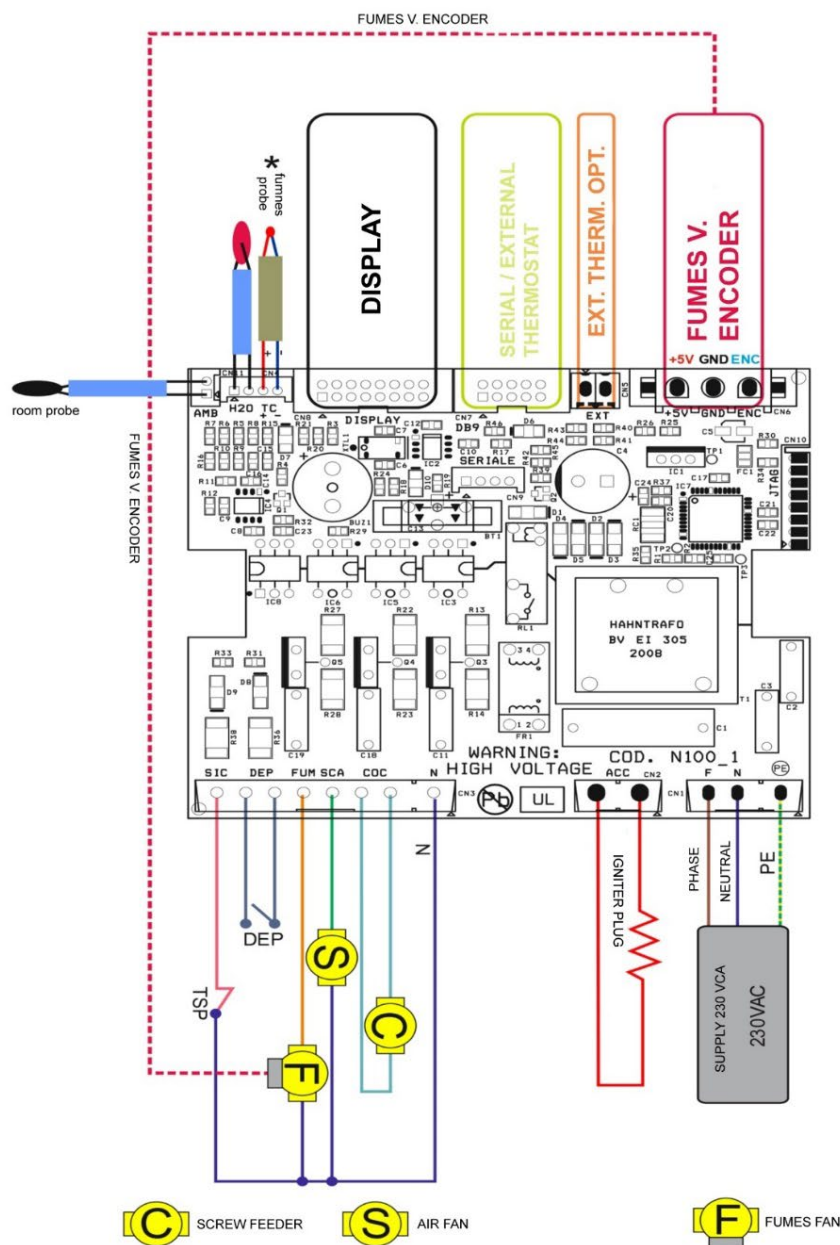

2.4.2 Eolo Air

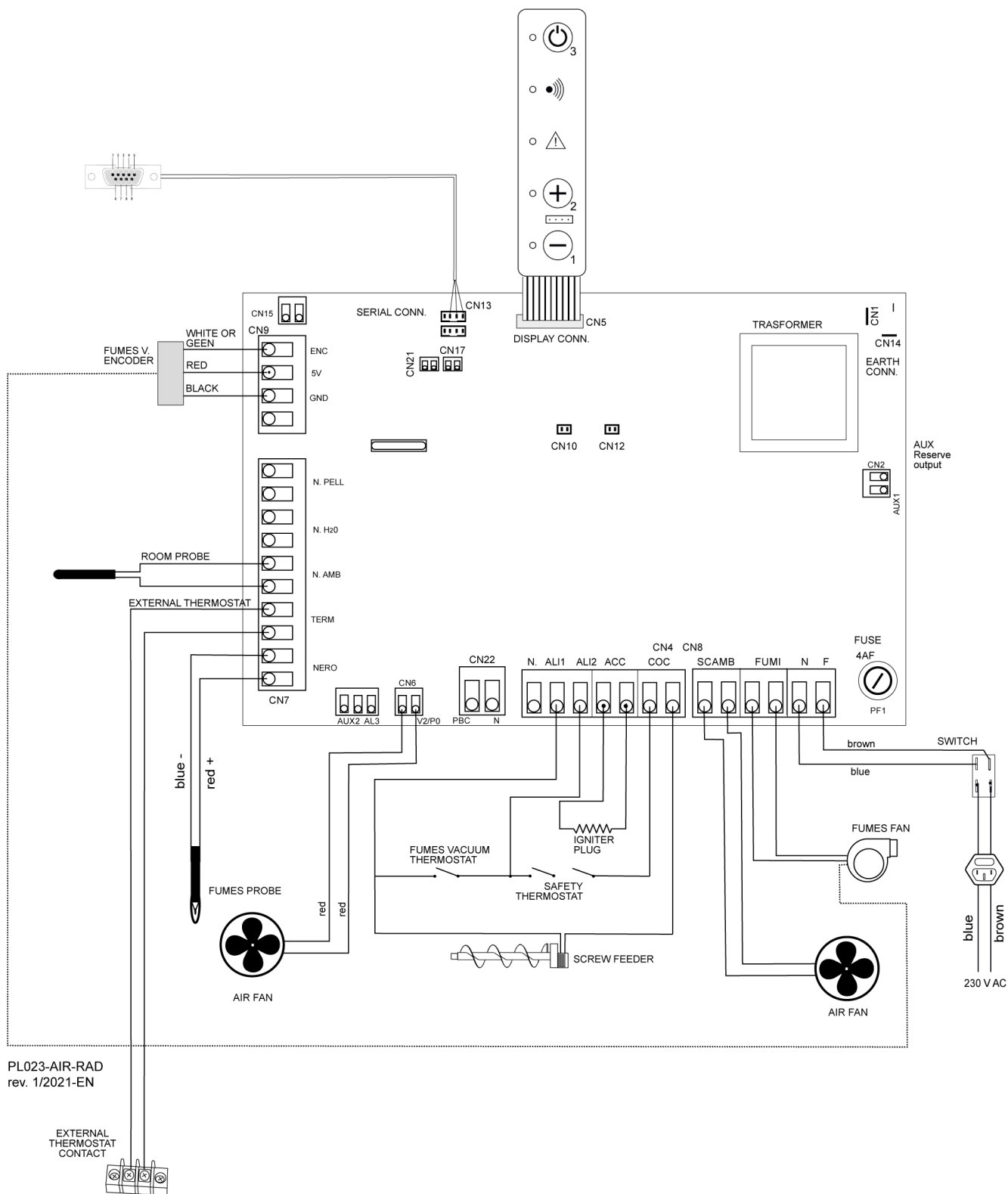

3 FUEL

3.1 General notes

The pellet fireplace is designed to burn wood pellets only.

Wood pellets are a fuel obtained from the pressing of sawdust timber, extracted from the processing and transformation residues of dried wood material. The compactness of the product over time is guaranteed by a natural origin substance contained in the wood: lignin. The typical small cylinder form is obtained by extrusion.

Various types of pellets with quality and characteristics that vary depending on the processing and type of wood species used are available on the market.

CAUTION: Always use certified quality wood pellets: i.e. DIN, DIN PLUS, ÖM 7135, Pellet Gold, Catas etc. The company does not guarantee proper fireplace functioning with the use of low-quality pellets.

Fireplaces and heating fireplaces are tested and programmed to ensure good performance and perfect quality operation with specific characteristic pellets:

Components:	Wood
Length:	< a 30 mm
Diameter:	6-6.5 mm
Lower calorific value :	4,8 kWh/kg
Humidity rate:	< a 8 %
Residual ash :	< a 0,5 %

GOOD QUALITY pellets are smooth, shiny, slightly dusty and with regular length.

LOW QUALITY pellets are of varied lengths, dusty with vertical and horizontal splits.

Since pellet characteristics and quality greatly influence the autonomy, efficiency and proper operation of the fireplace, we recommend:

AVOID using pellets with dimensions different from that described by the manufacturer.

AVOID using low quality pellets or pellets containing dispersed sawdust powder, resins or chemicals, additives or adhesives.

AVOID using moist pellets.

The use of unsuitable pellets causes:

- clogging of the brazier and fume discharge ducts
- increased consumption of fuel
- decreased efficiency
- no guarantee of normal fireplace operation
- dirtying of glass
- production of unburned granules and heavy ash

The presence of moisture in pellets increases the volume of the capsules and crumbles, causing

- feeding system malfunctions
- poor combustion

Pellets should be stored in a dry and sheltered place. Particular attention should be given to the handling of the bags to prevent their crushing, resulting in the formation of sawdust.

Fireplace operation parameters may have to be altered when using quality pellets with dimensional and calorific characteristics different from those indicated. Contact an authorised service centre if necessary.

THE USE OF POOR-QUALITY PELLETS NOT IN ACCORDANCE WITH MANUFACTURER'S INSTRUCTIONS NOT ONLY DAMAGE THE FIREPLACE AND COMPROMISE PERFORMANCE BUT MAY RESULT IN FORFEITURE OF THE WARRANTY AND COMPANY LIABILITY.

4 ASSEMBLY

4.1 General notes

Here are some general recommendations to follow in order to prevent accidents or damage to the product:

- Unpacking and installation must be performed by at least two people.
- **All handling operations must be carried out using appropriate means and in full compliance with safety regulations.**
- The positioning of the packed product must be maintained in accordance with the guidelines supplied by pictograms and written on the packaging.
- If using ropes, straps, chains, etc., make sure they are suitable for the weight to be unloaded and are in good condition.
- When moving the package, move with slow and continuous movements to avoid tearing ropes, chains, etc
- Do not tilt excessively in order to avoid overturning.
- Do not stand within range of the loading/unloading means (forklifts, cranes, etc.).

4.2 Unpacking

Unpack the product being careful not to damage or scratch it. Remove the accessory package and any pieces of polystyrene or cardboard used to block removable parts, etc. from the fireplace furnace. Take out the envelope with the user manual and the guarantee usually placed either in the combustion chamber or in the pellet tank.

Also remember not to leave packaging components (plastic bags, polystyrene, etc.) within the reach of children, as they could be potential sources of danger. Dispose of them according to regulations

4.3 Installation and assembly

The product can be installed at the desired height, using the special adjustable structure (optional), or by building support and non-flammable supports able to withstand the product weight.

The company denies any liability for damages to property or persons in case the aforementioned warnings are not complied with.

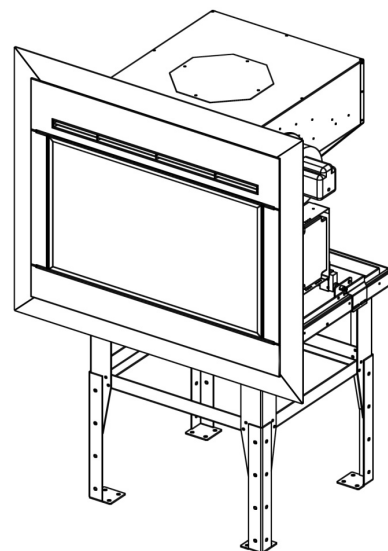

Fig.16

If the pellet insert is to be installed on a different structure or wall base, proceed as follows:

Remove the two front stop screws

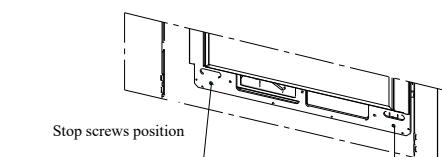

Fig.17

Remove the base from the fireplace by sliding it on the guides until fully extracted

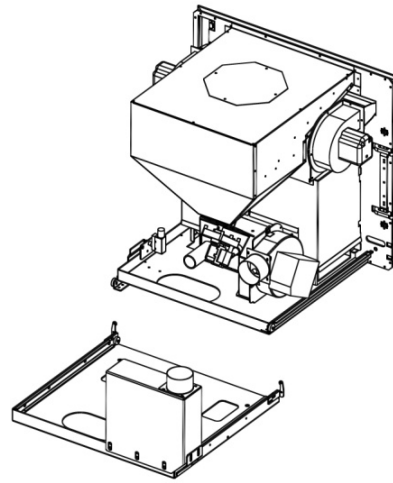

Fig.18

Place the base on the structure or on the wall support that has been prepared, leaving 14 mm from the front wall.
Fix the base using 5 wall plugs or screws

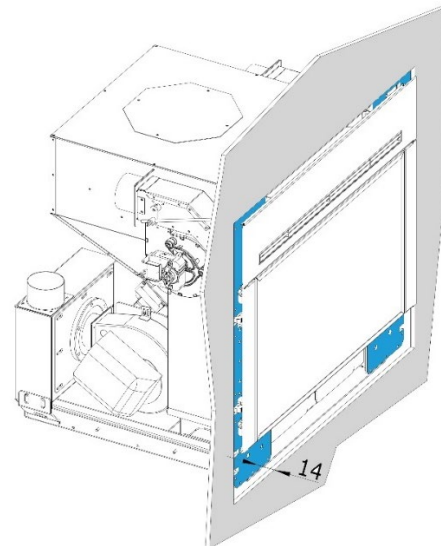

Fig.19

Before repositioning the fireplace insert on the guides, make all the following fume, and electrical connections. Close the fireplace making sure that it has reached stroke end. The presence of the position sensor does not allow ignition if installation is incorrect. Refit the stop screws.

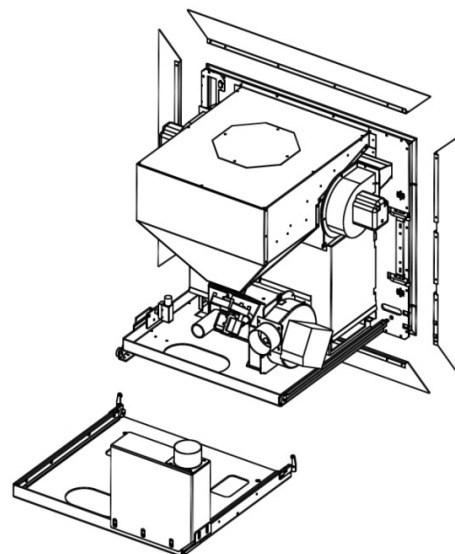

Fig.20

4.4 Electrical connection

The fireplace insert is supplied with a power cable that must be plugged into a 230V 50Hz outlet. Outlet connection in the rear of the fireplace is illustrated in *Fig. 15*. Absorbed power is indicated in the product technical sheet, which can be downloaded from the website www.laminox.com. By law, the system must be properly grounded and with a differential circuit-breaker. Make sure that the electrical power cable does not come into contact with hot parts when set in its final position.

- Connect the cable supplied to an earthed power socket.

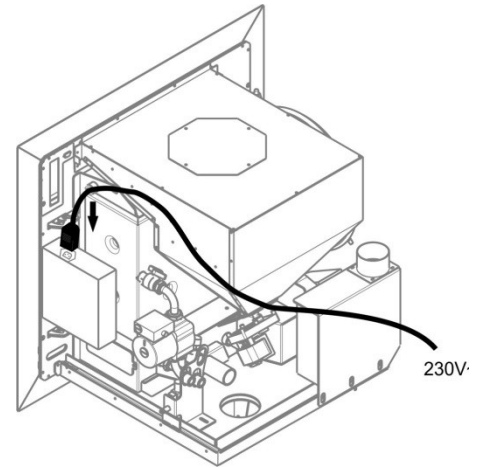

Fig. 21

CAUTION: Ensure that the plug for the electrical connection remains accessible after fireplace insert installation

4.5 Fume duct connection

In making the hole for the fume exhaust pipe, it is necessary to consider the possible presence of flammable materials. If the hole is to cross a wooden wall or thermolabile material, the installer must use a wall fitting and adequately insulate the product pipe that crosses it using adequate insulating materials (thick. 1.3

- 5 cm with min thermal conductivity of $0.07 \text{ W/m}^\circ\text{K}$). The same minimum distance must be respected even if the exhaust pipe must travel vertical or horizontal sections always near the thermolabile wall. For all information regarding the various cases of fume duct installation, refer to the previous chapter.

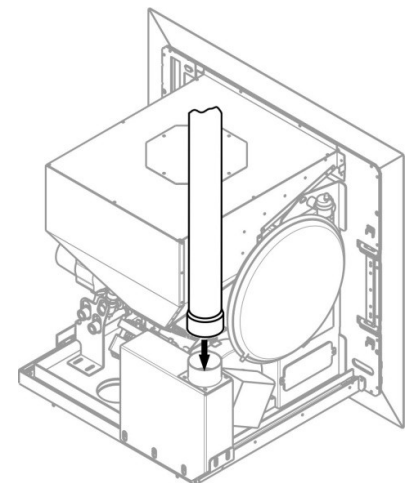

Fig. 22

4.6 Primary air

To perform the combustion, the product, during its operation, withdraws a certain amount of air from the environment; this air must be integrated through an air intake outside the room. In this product the combustion air inlet is direct so it is necessary to arrange grids in the casing surrounding the product, but if the user wants to take air from the outside, he/she must fit a pipe and connect it directly to the outside.

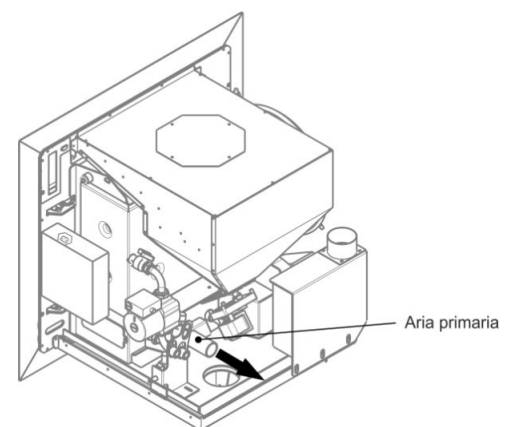

Fig. 23

4.7 External thermostat installation

Fireplace insert operation can be adjusted to any external room thermostat connected to the circuit board with a clean contact (see electrical diagram). The thermostat connection is made using a 2x0.5 mm² cable. The contact to be used is of the NO (Normally open) type, if there isn't a clean contact, insert a relay between the thermostat and the machine terminal board.

The connection of unsuitable thermostats could irreparably damage the electronic card.

This operation should be performed by qualified personnel.

The external thermostat works in parallel to the internal thermostat of the fireplace e to the one present in the remote radio control

if you choose to use an external thermostat, set the room temperature value on the remote control to the minimum (7°C). At this point, fireplace modulation will be controlled by the external thermostat.

During the working phase, if the room temperature is lower than the set temperature and the external thermostat is active (closed contact), the insert will operate at the set power level. When the room temperature reaches the set temperature, (external thermostat contact open), the fireplace will go to minimum power and the display will show the message "MODULATE". This modulation has been completed only if the room temperature returns to being lower than the set temperature in the external thermostat.

5 USE

- All local regulations, including those relating to national and European regulations, must be observed when installing the unit. Improper installation or use of the device can result in forfeiture of the warranty.
- Do not use the unit as an incinerator or in any other way other than that for which it was designed.
- **No other fuel besides wood pellets must be used. Do not use liquid fuels.**
- **The device, especially the external surfaces, gets very hot to the touch when in use. Handle with care to avoid burns.**
- Do not make any unauthorised modifications to the device. **Only use original replacement parts recommended by the manufacturer.**
- Make sure that the room where the fireplace is to be installed offers sufficient ventilation (see section "1.7 External air intake vent").
- Make sure that all exhaust system joints are hermetically sealed with silicone (no cementing), are resistant to heat (250 ° C) and are not damaged.
- Periodically check (or have someone check) the cleanliness of exhaust fumes.
- **CAUTION:** keep all flammable products well away from the fireplace when it operating (MINIMUM: 100 cm from the front wall).
- **CAUTION: to prevent the escape of fumes, the combustion chamber must be kept closed except during cleaning operations, to be carried out with the fireplace off.**
- **CAUTION: removing the safety guard inside the tank is strictly prohibited.**
- **CAUTION: in case of pellet resupply with fireplace on, make sure that the pellet has not ended and the flame is always present in the brazier. If the flame is extinguished a dense white smoke may form, able to cause an explosion in the combustion chamber. The explosion can be of such intensity as to break the glass of the fire door. Therefore, pay attention to never stay in front of the fireplace during ignition stage if the fuel releases a dense smoke. The fireplace is however equipped with all safety systems required to minimize the glass breakage risk.**
- **CAUTION:** prevent the fuel bag to come into contact with hot surfaces.
- **CAUTION:** remove any residue of unburned pellets caused by failed ignitions before you start the fireplace again.
- **CAUTION:** if during the ignition phase, the fireplace does not start and you notice a lot of smoke in the combustion chamber, immediately turn off the fireplace and replace pellets in use, as these may be too high in moisture. **Forcing ignition could make your fireplace a hazard.**
- **CAUTION:** if during cleaning, you find traces of spongy or hard (though not ash) pellets, replace the pellets being used as this residue may come from scraps of low-quality sawdust not usable in this type of fireplace. Forcing ignition can cause a fire or strong production of fumes in the chimney.
- **CAUTION:** monitor proper combustion of the pellets in the brazier. **If you should detect accumulations of unburned pellets, IMMEDIATELY TURN OFF the fireplace and contact the service centre.**
- **CAUTION:** exercise extreme caution in the presence of children, to prevent them from standing in front of the fireplace.



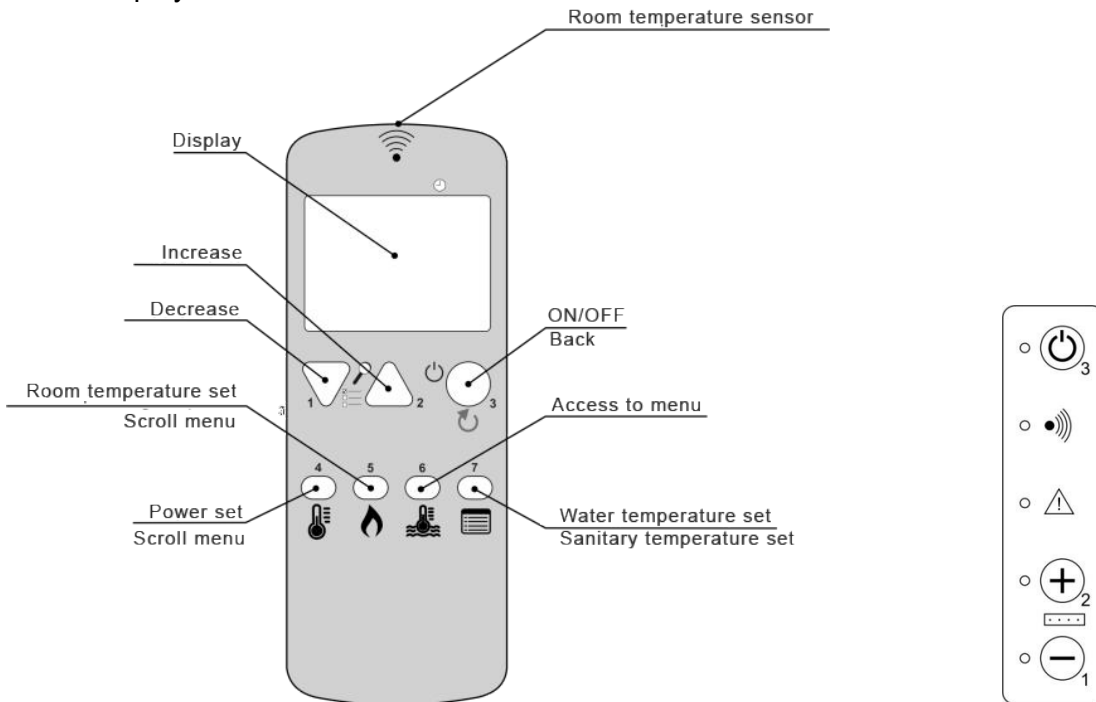

5.1 Remote control description

The console displays information about fireplace operating status. Access the menu to view various types of displays and adjust the settings available depending on the level of access.



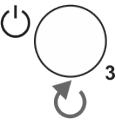
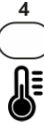

Depending on the operating mode, the displays may have different meanings based on their position on the display.



5.1.1 Console button functions

 1	KEY 1 POWER REDUCTION	Functions: Reduction in set power value or reference value being set
 2	KEY 2 POWER INCREASE	Functions: Increase in set power value or reference value being set
 3	KEY 3 ON-OFF	Functions: <ul style="list-style-type: none"> Manual start-up and shut-down of the fireplace Exit from the programming status Exit from the menus Exit from shut-down or alarm (and passage to off status)
 4	KEY 4 TEMPERATURE ADJUSTMENT	Functions: <ul style="list-style-type: none"> Switching to room temperature setting Scrolls the menus down In technical parameter setting mode, it scrolls the sub-menu
 5	KEY 5 POWER ADJUSTMENT	Functions: <ul style="list-style-type: none"> Switching to power setting Scrolls the menus up In technical parameter setting mode, it scrolls the sub-menu
 7	KEY 7 SETTING SELECTION	Functions: <ul style="list-style-type: none"> Switching to menu functions Switching to programmable thermostat and clock programming Switching to technical parameters programming

As for the LEDs present on the fireplace insert console, the meaning is the following:

	Power LED	Indicates ignition
	Alarm	Indicates the alarm status of the fireplace insert
	Power	Pressing the corresponding key takes the fireplace insert to power 5
	Power	Pressing the corresponding key takes the fireplace insert to power 2

5.1.2 Battery replacement

Remove the remote control rear shell

Replace the batteries paying attention not to reverse the polarity

The batteries must be **AAA (LR03) 1.5V**

5.1.3 Transmission unit setting

The fireplace must be connected to the power mains

- Press keys 1-2 simultaneously (up arrow and down arrow) for about 3-4 seconds until the SELECT UNIT message appears
- Select the transmission unit with the 1-2 keys (1-2-3...)
- the remote controls are provided with transmission unit set to 0 (default unit)
- Turn the fireplace off and on again.
- To memorise, hold-down key 3 (on-off) for about 3 seconds, a BEEP will signal the made memorisation and connection.
- The remote control is ready for normal operation.

5.1.4 Backlight setting

Pressing the P1-P7 keys together selects the duration of the backlight.

By default, the backlight is Off

5.2 First ignition

Before igniting the fireplace, you **MUST** have a qualified technician perform "FIRST IGNITION" and calibration. For this purpose, we advise you to contact personnel part of our network of authorised service centres.

The company assumes no responsibility for malfunctions due to improper installation, failure to install, incorrect first ignition, or improper use.

Make sure that electrical connections have been performed properly.

The first few times you light the fireplace, it may give off odours due to the evaporation of paint or grease. Simply ventilate the room to make the odour go away, avoiding prolonged exposure as vapours can be harmful to people or animals. Do not allow children to stay in the room during this first phase.

When the tank is loaded for the first time, the feed screw must fill up for a given period. During this time, pellets will not be distributed within the combustion chamber. To overcome this difficulty, use the command "Initial load" in menu 7 of the control panel (*see further details to follow*).

5.3 Pellet load

Pellet must be loaded through the front removable drawer located above the fire door. Follow thesequence below to facilitate loading:

- Open the drawer all the way, the sliding guides will block its movement at maximum extraction. If the fireplace is hot, use an oven glove.
- Gradually pour the pellet inside the drawer using a shovel (not supplied).
- Move the drawer back and forth for the pellet to slide to the bottom of the tank.

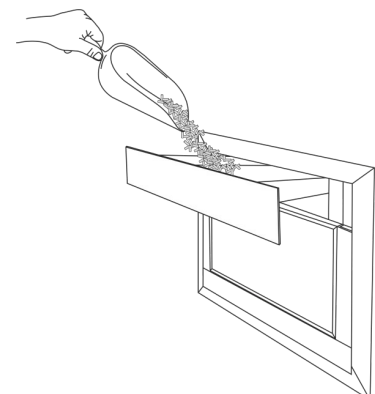

5.4 Ignition and normal operation

Before igniting the fireplace:

- **Check that the furnace door is locked.**
- Make sure that the pellet tank is full or contains such enough so that the fireplace will function for the desired amount of time.
- **Make sure that the brazier is clean**, free of ashes, combustion residue or unburned pellets (if necessary, remove the brazier and thoroughly clean it, then replace it with care in its housing).
- In the event or start-up with the programmable thermostat, make sure that the brazier is in the indicated conditions after last use.

When the fireplace is connected to the electrical system but not in work mode, the display will show the message "OFF".

5.4.1 Fireplace start-up

To start up the fireplace, hold and press the start button (4) for 2 seconds

If you start the fireplace during the final cleaning phase, the display may show the message "WAIT COOLING." In this case, wait for a minute before retrying ignition

First phase - Preparation

The message "START" will appear on the display. In this phase, which lasts for about one minute, the pellet glow plug activates and combustion chamber forced ventilation starts along with activation of the fume extraction fan.

Second phase – Ignition

After the preparation phase, the display will show the message "LOAD PELLETS" and ignition will begin. This second phase is divided in two parts: pre-loading and actual ignition. First, the pellet feed screw is activated (the Feed screw ON LED  lights up) for a variable time interval, depending on the model, and pellets begin to fall inside the brazier.

Remember that the brazier must be perfectly clean at this beginning of this stage.

Once this "pre-loading" phase is completed, the pellet feed screw will stop for a variable amount of time depending on the model (from two to three minutes). After this waiting phase, the pellet feed screw will start to switch on at regular intervals and pellets will then continue falling inside the fireplace brazier, while the glow plug and then fume exhaust fan will both remain activated.

As soon as the pellets cover the glow plug hole, you will notice first a reddening and then the onset of a small flame in the brazier.

If pellets continue to fill the brazier without this happening, manually stop the ignition process without waiting for the fireplace to set off an alarm: "AL 5 NO START".

This second phase is completed when the fireplace detects successful triggering of the combustion process, or rather after 4-5 minutes from the triggering of the first flame.

If combustion is not detected within a given amount of time, the no start-up alarm will be activated ("AL 5 NO START" message).

Third phase - Stabilization

Once combustion triggering has been detected, the third phase will start and the display will show the message "FIRE PRESENT". Pellet feeding is reduced and ventilation increased in order to allow a stabilisation of the flame and disposal of excess pellets accumulated in the brazier during the ignition phase. This phase lasts about 5 minutes.

Once the stabilisation phase has been completed ("FIRE PRESENT"), the fireplace passes to the normal working phase.

5.4.2 No start-up

As said, if the onset of combustion is not detected, the no start-up alarm will be set off. The display will show the message "AL 5 NO START" and an acoustic signal will be heard at regular intervals (if the buzzer function is active in Menu 6).

To disable the alarm, hold and press the ON-OFF (4) (about 2 secondi). The acoustic alarm will stop and the fireplace will return to "FINAL CLEANING" status and then to "OFF."

Before starting another ignition cycle verify the cause of the alarm, specifically

- **Verify that the pellet tank is not empty.**
- **Verify that the brazier is in the right position.**
- Remove the unburned pellets from the brazier (**VERY IMPORTANT**).

CAUTION: An excessive quantity of pellets in the brazier, a humid pellet or dirty brazier make the ignition stage difficult. If these critical conditions are present a dense white smoke capable of causing an explosion in the combustion chamber may form. The explosion can be of such intensity as to break the glass of the fire door. Therefore, pay attention to never stay in front of the fireplace during ignition stage if the fuel releases a dense smoke.

The fireplace is however equipped with all safety systems required to minimise this risk.

If the device does not ignite regularly, the main cause may be insufficient maintenance or poor pellet quality.

5.4.3 Normal operation

As soon as the ignition phase is over, the fireplace will go into normal working mode.

During this phase, the display will show the following information:

- The first line shows the time.
- The second line shows the room temperature
- The third line shows the message "WORK". while the line on the right shows set power.
- The fourth line shows the message "MODULATE" when room temperature reaches the set temperature (see corresponding paragraph).

During normal working mode, the following operations can be performed:

- Fireplace power setting, choosing from one of the five available levels. The power is set using key "5" and keys "1" and "2".
- Desired room temperature setting, choosing an interval from 7°C to 40°C. Press "4" once and then set the temperature with button "2" to increase and "1" to decrease.

Periodic brazier cleaning is also active during working mode. Brazier cleaning mode is activated at regular intervals of about one hour. In this way, the smoke extractor works at maximum power while pellet feeding is reduced to minimum. This operation is necessary for eliminating ash deposits inside the brazier and for ensuring proper aeration and combustion. During brazier cleaning, the display will show the message "BRAZIER CLEANING". **If you notice excessive accumulation of pellets in the brazier during normal operation, turn off the fireplace immediately and contact a service centre. Forcing could make your fireplace a hazard.**

5.4.4 Modulation based on room temperature

The fireplace is equipped with an internal temperature sensor that allows it to modulate its power according to the desired room temperature.

For correct environment sensor operation, verify that the room sensor positioned in the rear of the fireplace under the outlet (*Fig 15*) is away from the fume exhaust pipe and is not in contact with objects or walls.

Press button "2" to set room temperature. The message " SET ROOM TEMP" will appear on the bottom of the display, while the upper part will show the set temperature. To modify this value, use buttons "1" and "2" until you reach desired temperature (7°C to 40°C).

If the room temperature reaches the set temperature, the fireplace goes into minimum power and the last line of the display shows "MODULATE." This modulation has been completed only if the room temperature returns to being lower than the set temperature. In this case, the fireplace will return to the power set by the user and the display will show the message "MODULATE" and standard working indications will return

5.4.5 Ventilation

Air models provide ventilation which diffuses the heat generated from by the fireplace into the surrounding environment. Activation of the ventilation occurs based on the temperature of fumes. Therefore, it starts up after ignition and switches off with a delay compared to fireplace shutdown. Ventilation speed is proportional to operating power and cannot be modified independently with respect to fireplace power.

5.4.6 Channeling

In the ducted version it is possible to choose whether to send the hot air into the front or into the air channelling duct.

Each channel can be adjusted independently using two levers positioned on the front which can be accessed by opening the pellet loading drawer

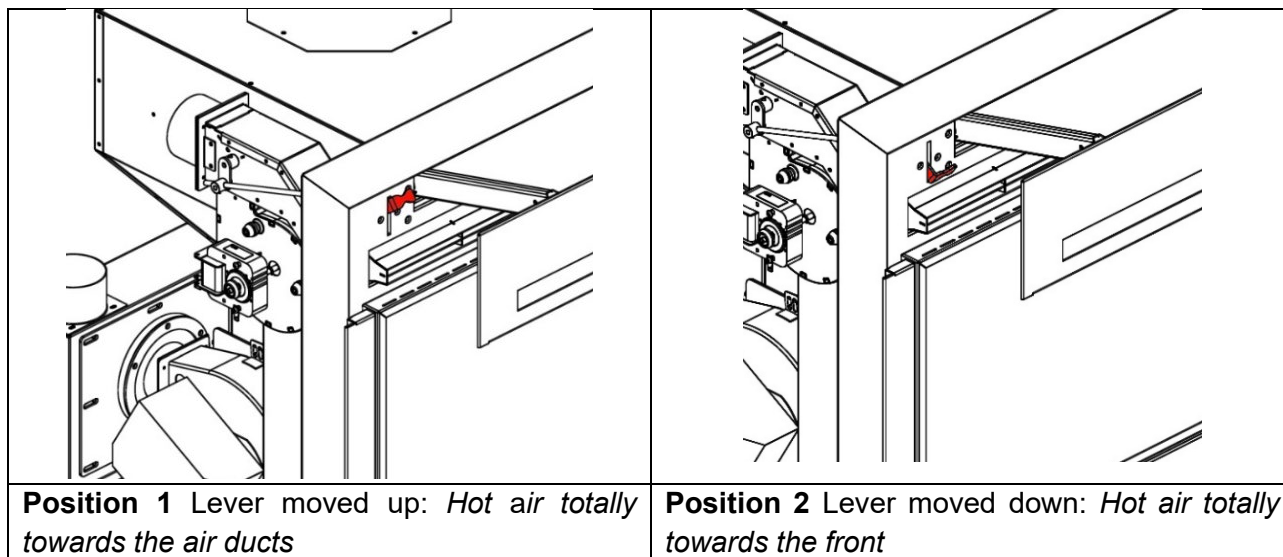

Intermediate positions: *The hot air goes partly towards the front and party towards the air ducts*

5.4.7 Brazier cleaning

During normal operation in work mode, "BRAZIER CLEANING" is activated at set intervals. During this time, the display will show the message "BRAZIER CLEANING", fireplace ventilation increases and the flame lowers in the brazier. This operation is necessary to decrease the likelihood of ash accumulation of ash inside the brazier.

If you notice an excessive accumulation of pellets in the brazier (over half the level of the brazier itself), immediately switch off the fireplace and clean the brazier. Promptly contact a service centre.

5.4.8 Shutdown

To turn off the fireplace, hold button 4 for a few seconds.

Once the shutdown signal has been received, the display will show a "FINAL CLEANING" message and the fume exhaust fan will continue to run at full speed for a minimum time of about 10 minutes to ensure complete cooling of the fireplace. The hot air fan will also continue to run until the fireplace cools down.

CAUTION: Never disconnect the power supply at this stage, as this may create problems for the fireplace and compromise the subsequent phases of ignition.

5.4.9 Interruption of power supply

In the event of a brief interruption in the power supply (under 10 seconds), the fireplace will automatically re-start without any alarms.

If power is lost for a longer time and the fireplace was in work mode, an "AL 1 - BLACK OUT" alarm will be generated. The fireplace will therefore not start back up automatically, but first the alarm will need to be manually removed

6 MENU

Press button "7" (MENU) to access the menu.

The menu is divided into different items and levels that allow you to access board settings and programming.

Menu items that allow you to access technical programming are protected by an access key.

6.1 Menu 01 "FANS ADJUSTMENT"

Menu item 01 "FANS ADJUSTMENT" is present only on channelled air models and allows you to modify the ventilation of the two channelled outputs. The choices shown in the table below are possible for each of the two fans. Press button "1" (fan 2) and "2" (fan 3) to select.

6.2 Menu 02 "CLOCK SET"

You can set the current time and date in this menu. The board is equipped with a lithium battery that allows internal clock autonomy over 3/5 years.

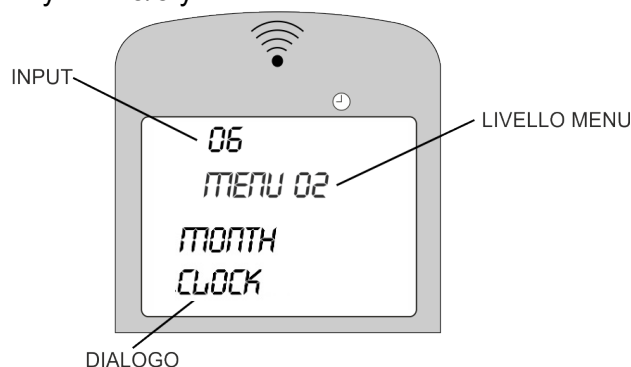

Enter into MENU and set, in order:

01	Day of the week	(Monday ... Sunday)
02	Hour	(0... 23)
03	Minutes	(0... 59)
04	Day of the month	(1...31)
05	Month of the Year	(1...12)
06	Current Year	(2000... 2099)

6.3 Menu 03 "CHRONO SET"

Use this menu to enable and programme start-ups and shutdowns. There are eight different possibilities divided into three groups:

- **Daily programme:** 2 start-ups and shutdowns valid each day.
- **Weekly programme:** 4 start-ups and shutdowns, for which you can decide which days of the week they must be active.
- **Weekend program:** 2 start-ups and shutdowns valid only for Saturday and Sunday.

Below is the diagram of the various Menu levels. Access the menu by pressing "3", return to the previous menu by pressing "4", scroll through the menu by pressing "5" and "6" and change the value by using keys "1" and "2"

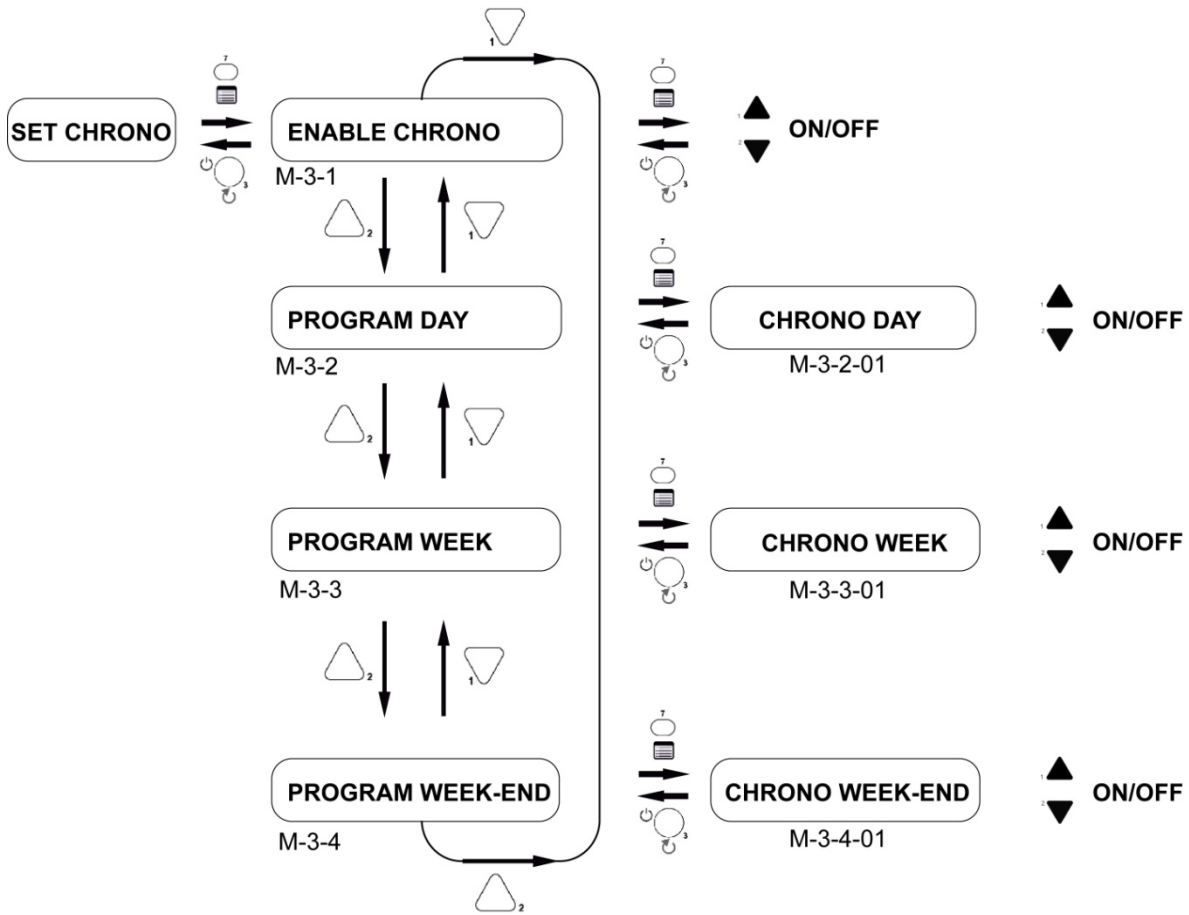

6.3.1 Menu 3-1 “ENABLE CHRONO”

Allows you to enable and disable all programmable thermostat functions.
 If the value is "off", all set programmes are disabled

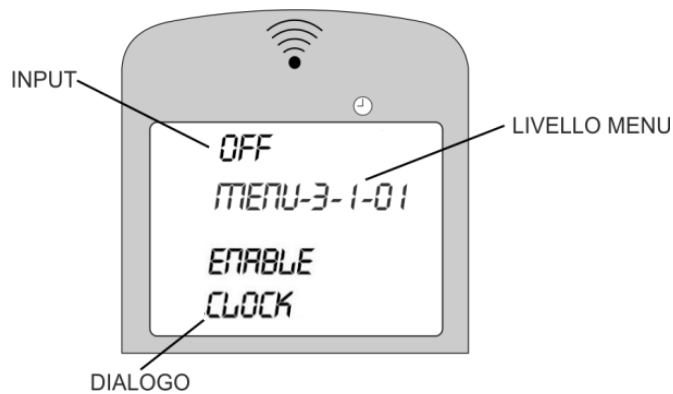

6.3.2 Menu 3-2 “DAILY PROGRAMME”

Allows you to enable, disable and set all programmable thermostat functions.

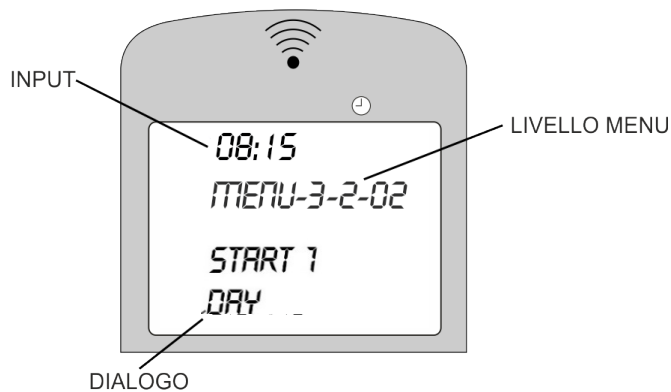

After having set the first parameter (M-3-2-01) "DAILY CHRONO" to "On", you can set two start-ups and two shutdowns. For each parameter, you can either set the value "Off", if you do not wish to activate, or the time of start-up or shutdown.

<i>Menu level</i>	<i>Selection</i>	<i>Meaning</i>	<i>Possible values</i>
M 3-2-02	START 1	Activation Time	00:00-23:50 -OFF
M 3-2-03	STOP 1	Disable time	00:00-23:50 -OFF
M 3-2-04	START 2	Activation time	00:00-23:50 -OFF
M 3-2-05	STOP 2	Disable time	00:00-23:50 -OFF

6.3.3 Menu3-3 "WEEKLY PROG"

The weekly programming group includes 4 start-ups and 4 shutdowns. For each on-off pair, you can decide which day of the week to activate the corresponding pair controls.

With the first parameter, M-3-3-01 "WEEKLY CHRONO", you can enable or disable all weekly programmable settings

After having set the first parameter (M-3-2-01) "WEEKLY CHRONO" to "on", you can set 4 start-ups and 4 shutdowns. For each parameter, you can either set the value "off", if you do not wish to activate, or the time of start-up or shutdown. After each pair of on and off times, there are 7 parameters corresponding to the 7 days of the week. Each of these parameters can be set to "On" or "Off" based on which programming you wish to activate corresponding to that day of the week. (See following tables).

PROGRAMME 1			
<i>Menu level</i>	<i>Selection</i>	<i>Meaning</i>	<i>Possible values</i>
M 3-3-02	START PROG 1	On Time	00:00-23:50 -OFF
M 3-3-03	STOP PROG 1	Off Time	00:00-23:50 -OFF
M 3-3-04	MONDAY PROG 1	Reference day	on/off
M 3-3-05	TUESDAY PROG 1		on/off
M 3-3-06	WEDNES-PROG 1		on/off
M 3-3-07	THURSDAY PROG 1		on/off
M 3-3-08	FRIDAY PROG 1		on/off
M 3-3-09	SATURDAY PROG 1		on/off
M 3-3-10	SUNDAY PROG 1		on/off

PROGRAMME 2			
<i>Menu level</i>	<i>Selection</i>	<i>Meaning</i>	<i>Possible values</i>
M 3-3-11	START PROG 2	On Time	00:00-23:50 -OFF
M 3-3-12	STOP PROG 2	Off Time	00:00-23:50 -OFF
M 3-3-13	MONDAY PROG 2	Reference day	on/off
M 3-3-14	TUESDAY PROG 2		on/off
M 3-3-15	WEDNES-PROG 2		on/off
M 3-3-16	THURSDAY PROG 2		on/off
M 3-3-17	FRIDAY PROG 2		on/off
M 3-3-18	SATURDAY PROG 2		on/off
M 3-3-19	SUNDAY PROG 2		on/off

PROGRAMME 3			
Menu level	Selection	Meaning	Possible values
M 3-3-20	START PROG 3	On Time	00:00-23:50 -OFF
M 3-3-21	STOP PROG 3	Off Time	00:00-23:50 -OFF
M 3-3-22	MONDAY PROG 3	Reference day	on/off
M 3-3-23	TUESDAY PROG 3		on/off
M 3-3-24	WEDNES-PROG 3		on/off
M 3-3-25	THURSDAY PROG 3		on/off
M 3-3-26	FRIDAY PROG 3		on/off
M 3-3-27	SATURDAY PROG 3		on/off
M 3-3-28	SUNDAY PROG 3		on/off

PROGRAMME 4			
Menu level	Selection	Meaning	Possible values
M 3-3-29	START PROG 4	On Time	00:00-23:50 -OFF
M 3-3-30	STOP PROG 4	Off Time	00:00-23:50 -OFF
M 3-3-31	MONDAY PROG 4	Reference day	on/off
M 3-3-32	TUESDAY PROG 4		on/off
M 3-3-33	WEDNES-PROG 4		on/off
M 3-3-34	THURSDAY PROG 4		on/off
M 3-3-35	FRIDAY PROG 4		on/off
M 3-3-36	SATURDAY PROG 4		on/off
M 3-3-37	SUNDAY PROG 4		on/off

6.3.4 Menu 3-4 “WEEK-END PROG”

Allows you to enable, disable and set programmable thermostat functions for the weekend (Saturday and Sunday). As per daily programmes, we have an enabling parameter and 2 pairs of start-up and shutdown times. Programming will be active as stated only on Saturday and Sunday.

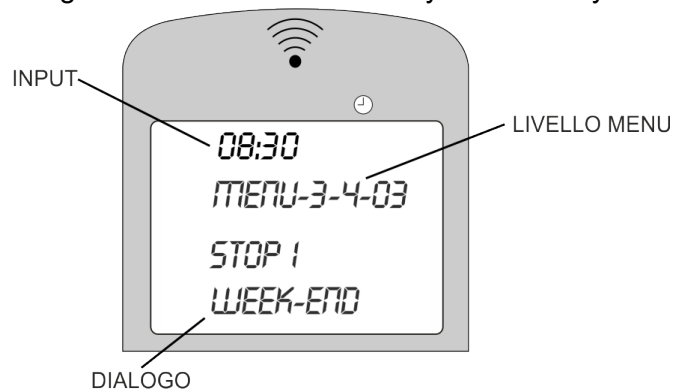

TIP: to avoid confusion and unwanted start-up and shutdown, activate only one programme at a time if you do not know exactly what your desired programming is. Disable the daily programme if you want to use weekly programming. Always disable the weekend programme if you are using weekly programmes. Activate the weekend programme only after having disabled weekly programming.

6.4 Menu 04 “CHOOSE LANGUAGE”

Allows you to select the dialogue language among those available.

6.5 Menu 05 "CHOOSE PROBE"

It allows to choose whether to use the room probe integrated on the remote control or the one inside the fireplace insert

6.6 Menu 06 "STAND-BY MODE"

This menu allows you to activate or deactivate "STAND-BY". (Default setting is "OFF")

Stand-by mode indicates a condition in which the fireplace shuts off but where it automatically re-ignites as soon as the room temperature fall below the set value and the flue gas temperature drops below its threshold (fireplace is cold).

Once the stand-by Menu is set to a value between 1'-120', if the room temperature exceeds a certain amount, set values (2°C), an alternating message "MODULATE / OK STD BY" appears on the screen. At this point, after a pre-set time (default 10 minutes), if temperatures do not return under the set values, the fireplace shuts off and goes into stand-by mode.

During shutdown, the display shows the message "WAIT COOLING." This display message remains until re-lighting conditions are verified.

When the fireplace is controlled by an external thermostat, by activating the stand-by mode, it is possible to control ignition and shutdown directly from the thermostat.

6.7 Menu 07 "BUZZER MODE"

When "off," acoustic signal disabled in the event of an alarm. When "on," sets off a buzzer when an alarm is activated.

6.8 Menu 08 "INITIAL LOAD"

When the display shows the message "OFF," allows you to preload pellets for a time equal to 90 sec. Start by pressing button "1" and stop if desired by pressing button "4." Once preloading is completed, remove the loaded pellets from the brazier.

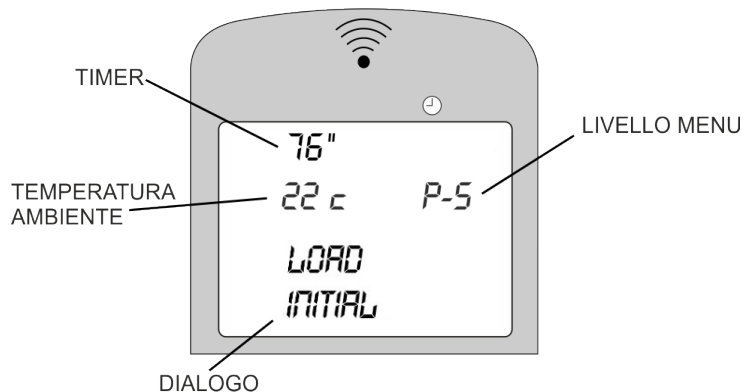

6.9 Menu 09 "FIREPLACE STATUS"

The fireplace status menu shows the current state of the fireplace, showing some sensor values and other variables inside the fireplace. Four pages displayed in succession are available.

This menu is for qualified service personnel use.

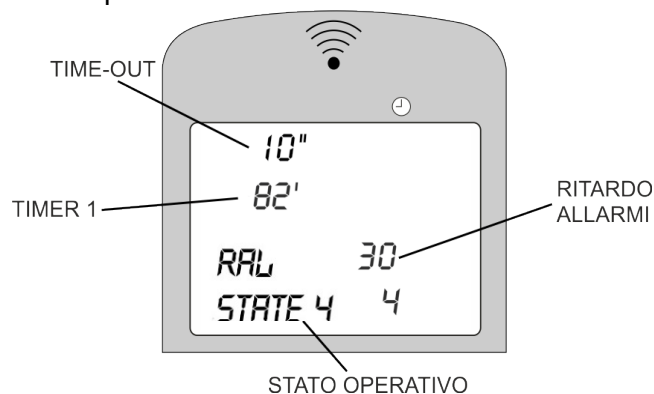

6.10 Menu 10 "TECHNICAL CALIBRATION"

This menu is protected by an access key and is intended for qualified service personnel.

6.11 Menu 11 "PELLET TYPE"

This menu allows you to simultaneously increase or decrease all pellet lowering parameters (quantity of pellets and brazier loading). The set default value is 00. Press keys (1) and (2) to modify said value from -9 to +9. For each unit, pellet load times are increased or decreased by 2.5 %.

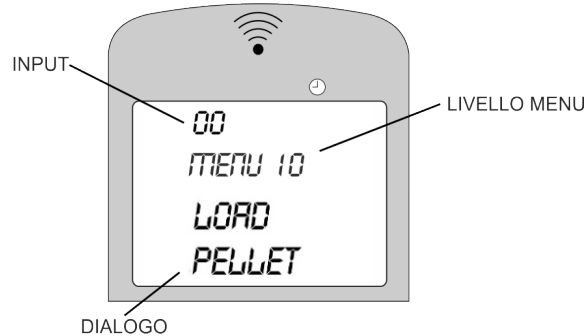

6.12 Menu 12 "FIREPLACE TYPE"

This menu allows users to simultaneously increase or decrease all smoke fan parameters (draft). The set default value is 00. Press keys (1) and (2) to modify said value from -9 to +9. For each unit, smoke motor revs are increased or decreased by 2.5%.

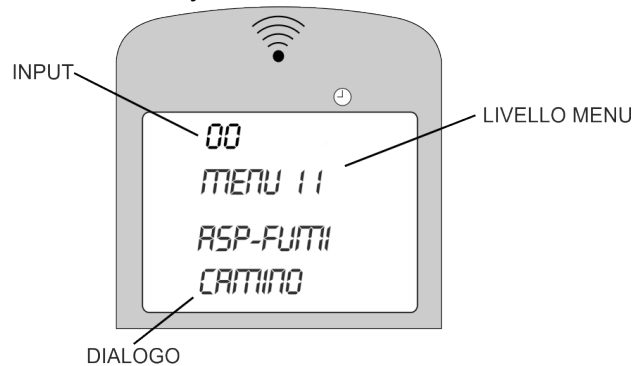

7 SAFETY AND ALARMS

7.1 Safety devices

CAUTION: During operation, some parts of the fireplace (door, handle, ceramic parts) can reach very high temperatures.

Remember to keep at the previously mentioned safe distance.

Be careful, **use caution** and always follow the instructions.

If during operations any part of the fireplace or the exhaust pipe leak smoke, immediately turn off the fireplace without removing the power supply and ventilate the room. Then, once cooled down, verify the reason for the leak and, if necessary, call service personnel.

The fireplace is equipped with several devices which intervene in order to ensure safe operation.

CAUTION: safety devices are designed to eliminate any risk of damage to persons, animals or things, and tampering with or servicing by unauthorised personnel could compromise their safety.

Safety devices on the fireplace include the following:

7.1.1 Fume exhaust pressure sensor

This sensor is connected to the fume exhaust pressure duct. It controls internal pressure to the duct, monitoring any occlusion of the chimney flue and allowing use of the fireplace in total safety.

When it activates

If proper operation conditions in the fume exhaust duct are altered (improper installation, the presence of obstacles or impediments in the exhaust tube, negligent maintenance, adverse weather conditions such as persistent wind, etc.), the pressure sensor (pressure gauge) stops electrical power supply to the pellet feed screw, thus blocking pellet feeding to the brazier and sending an alarm signal to the board.

The alarm can also be caused by clogging in the fireplace, by improper combustion or lack of annual fireplace cleaning.

When the alarm goes off, the display shows the message **"AL 8 – LOW PRESSURE"**.

7.1.2 Temperature sensor

The fireplace is equipped with a manual reset bulb thermostat whose function is to preserve the fireplace, pellet tank and, consequently, the whole structure from excessive temperature changes.

When it activates

If the pellet loading tube reaches the threshold of 85°C the thermostat interrupts electrical power to the feed screw, thus blocking pellet feeding to the brazier and sending an alarm signal to the board.

The display will show the message **"AL 7 – Thermal safety"**.

7.1.3 Smoke temperature sensor

The smoke sensor is directly connected to the circuit board and keeps operating temperature of exhaust fumes from the fireplace under constant control, allowing safe use of the fireplace.

How it works

If fume temperature exceeds the first pre-set temperature limit, the board passes into modulation mode. The display will show the message **"MODULATE / MAX SMOKE"**. At the same time if, despite passage to modulation, the fume temperature continues to increase and exceeds the second pre-set safety limit, the fireplace will pass into alarm mode. Pellet flow is interrupted and fume exhaust speed is set to maximum.

The display will show the message **"AL 3 – SMOKE TEMP"**.

The fireplace constantly controls smoke sensor functioning, If the sensor is momentarily and/or accidentally removed from its housing, or the connector is not correctly positioned on the circuit board or the sensor fails for any reason. The fault is signalled via display message **AL 2 – "SMOKE SENSOR"**

7.2 Alarms

In the event that an operating anomaly occurs, the board intervenes and signals the irregularities, operating in different modes depending on the type of alarm. The following alarms can occur:

Cause of alarm	Display message
No power	<i>AL1 BLACK-OUT</i>
Smoke temperature sensor	<i>AL2 SMOKE SENSOR</i>
Smoke overtemperature	<i>AL3 SMOKE TEMP</i>
Smoke fan fault	<i>AL4 EXTRACT FAULT</i>
No start-up	<i>AL5 NO START</i>
Shutdown during work mode	<i>AL6 NO PELLETS</i>
General safety thermostat	<i>AL7 THERMAL SAFETY</i>
Safety pressure switch	<i>AL8 LOW PRESSURE</i>

ALL ALARM CONDITIONS CAUSE IMMEDIATE FIREPLACE SHUTDOWN

To exit from an alarm condition, always press button "3" until the message "FINAL CLEANING" appears.

You will also need to take additional steps, depending on the type of alarm generated

If you do not exit from the alarm condition within a given time (a few hours), the alarm will be sent into fireplace memory and the display will show the message "ALARM MEMORY". To exit from this condition, press button "3" as per above.

AL 1 - Black-out

This alarm is activated when the fireplace is disconnected from the mains.

What to do

Put the fireplace in stand-by by pressing the off button for a few seconds.

AL 2 – Smoke sensor

This alarm signals breakage of the smoke sensor

What to do

- Put the fireplace in stand-by by pressing the off button for a few seconds.
- Wait and make sure that the combustion of pellets left in the brazier has been completed.
- If necessary, call a support centre to replace the sensor

AL 3 – Smoke temp

This alarm signals excessive smoke exhaust temperature (see safety devices)

What to do

- Put the fireplace in Off state by pressing the off button for a few seconds.
- Wait and make sure that the combustion of pellets left in the brazier has been completed.
- After having cleaned the brazier, restart the fireplace by pressing the key (3).
- If necessary, call a support centre to replace the sensor

AL 4 – Extract fault

This alarm indicates a failure to read the revs of the smoke expulsion motor by the control board. It may have been activated due to motor fault or due to a lack of connection between the rev reader (encoder) in the motor and the board.

What to do

Put the fireplace in Off state by pressing the off button for a few seconds. Try switching the fireplace back on.

Contact your support centre if the problem persists.

AL 5 - No start

This alarm signals an ignition failure. This alarm is activated when, during the start-up phase, a maximum waiting time (about 20 minutes) is exceeded without the machine switching on successfully. (See 5.3.1)

AL 6 - No pellet

This alarm indicates a flame failure in the brazier during normal fireplace operation. The main causes are: no pellets in the tank or blocking of the pellet feed screw.

What to do

- Put the fireplace in stand-by by pressing the off button for a few seconds.
- Empty the brazier of all unburned accumulated pellets.
- In the event of pellet exhaustion in the tank, refuel the fireplace and ignite it again. Do not insert pellets until the fireplace has cooled completely. **Pellet refilling must always be performed with the fireplace off or with the fireplace operating with the flame present.**
- In the case of a pellet feed screw block, empty the tank and remove any foreign bodies present in the feed screw. Then refill with pellets and start the fireplace back up
- **In the case of repeated feed screw blocks, call a support centre**

AL 7 – Thermal safety

This alarm is activated by intervention of the safety thermostat installed inside the fireplace

What to do

- Put the fireplace in stand-by by pressing the off button for a few seconds.
- Wait and make sure that the combustion of pellets left in the brazier has been completed.
- **Reset the safety thermostat** located on the rear of the fireplace under the outlet (*see fig. 15*).

Before resetting, make sure that the fireplace is **off and completely cooled down**, then proceed as follows:

- Unscrew the cap located on the rear of the fireplace (*see figure 15*);
- Press the red button applying a slight pressure;
- Re-screw the cap in its housing;
- **After having cleaned the brazier**, re-start the fireplace by pressing button 4;

AL 8 – No vacuum

This alarm is activated by intervention of the vacuum sensor (vacuum gauge)

What to do

- Put the fireplace in stand-by by pressing the off button for a few seconds.
- Wait and make sure that the combustion of pellets left in the brazier has been completed.
- Wait for the fireplace to cool down, then verify and remove the causes that triggered the safety device. Finally, after having cleaned the brazier, re-start the fireplace by pressing the ON/OFF button (4).

In the event of a repeated alarm, call the support centre.

Service

This warning appears on the display after a certain number of hours of operation.

It does not block the operation of the fireplace but warns that it is necessary to contact a Support center to have the extraordinary maintenance operations carried out on the product. (*see paragraph 8.13*)

8 WARNING AND MAINTENANCE

All maintenance operations (cleaning, replacements, etc.) should be carried out when the fire is out and the fireplace is cold. In addition, do not use any abrasive substances.

CAUTION: FAILURE TO CLEAN AFFECTS SAFETY

8.1 Opening the door

The door must remain closed during operation. The door should be opened only with the fireplace off and cooled down to perform maintenance and routine cleaning.

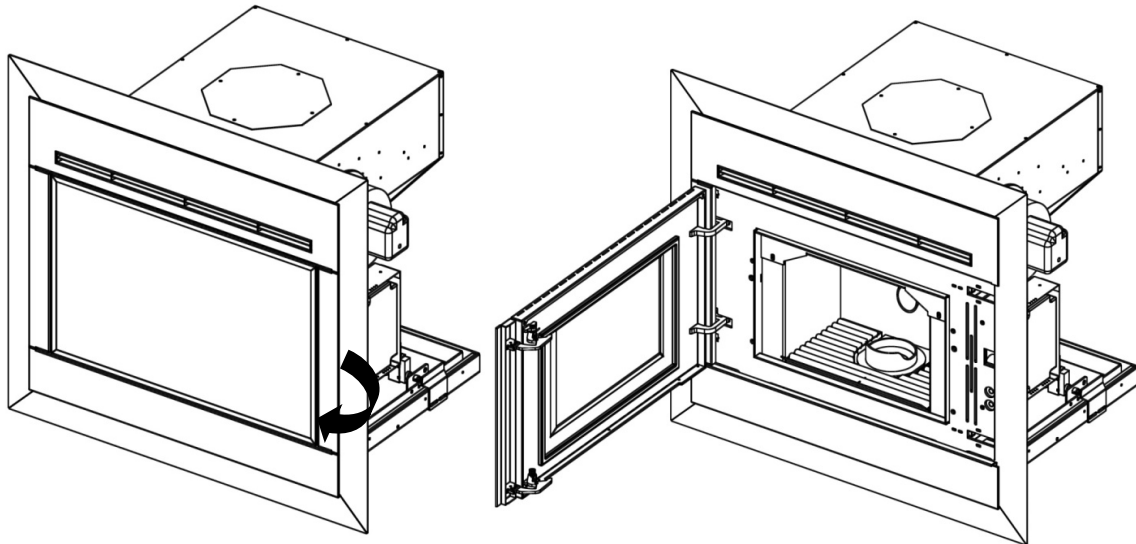

8.2 Ash drawer cleaning

Check the ash drawer every two days to see if it needs emptying

The ash collection compartment must be emptied regularly so as to impede combustion residue from arriving at the brazier support. Ashes must be placed in a metal container with a sealed lid. Until ashes are completely out, the sealed container should be placed on a non-combustible base or on the floor, or well away from combustible materials.

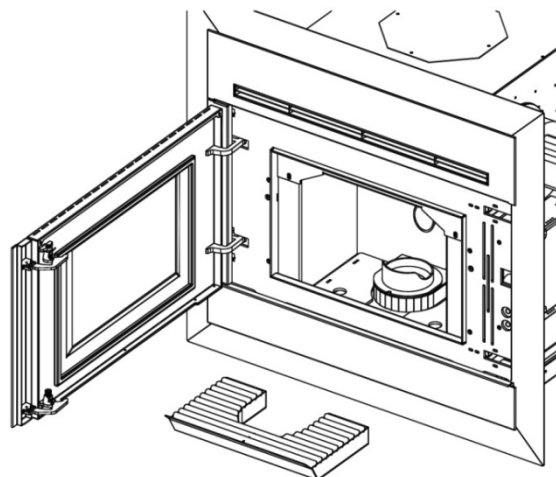

CAUTION: ashes keep embers on for a long time!!!

8.3 Brazier cleaning

When the flame becomes a red colour or is weak accompanied by black smoke, it may mean that there are ash deposits or incrustations which are not allowing correct fireplace operation and which must be removed.

Every two days, remove the brazier by simply lifting it from its housing, then clean it of ash and any incrustations which could have formed, with particular attention to freeing clogged holes using a pointed tool.

This operation is necessary in particular the first few ignitions, especially when using different quality pellets. The timing of this operation is determined by the frequency of use and the choice of fuel. It is advisable to also check the brazier support, emptying it of any ashes.

CAUTION: before igniting the fireplace, check that the brazier is pushed back toward the deflector and that the glow plug tube is inserted in the corresponding brazier hole.

8.4 Combustion chamber cleaning

Clean the combustion chamber weekly, removing ashes accumulated in the chamber using a vacuum cleaner.

Note Use a vacuum cleaner designed for the suction of ashes for this type of cleaning.

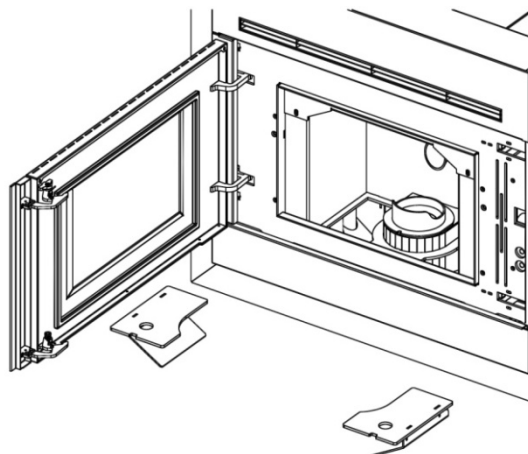

8.5 Smoke chamber cleaning

Generally, clean the smoke chamber once a year (preferably at the beginning of the season) for best fireplace operation. The frequency of this operation depends on the type of pellet used and the frequency of use.

Contact a Technical Assistance Centre for this type of cleaning.

8.6 Exhaust system cleaning

Until you are reasonably experienced regarding operating conditions, it is advisable to perform this service at least monthly. Remove the T-fitting cap and proceed with duct cleaning.

If necessary, at least the first few times, request assistance from a qualified technician.

8.7 Cleaning metal and ceramic parts

Use a soft cloth moistened with water to clean metal fireplace parts.

Never clean metal or ceramic parts with alcohol, thinners, petrol, ketones or other degreasers.

Use of these substances frees the company from all liability. Discolouration of metal parts can be the result of improper use of the fireplace

8.8 Cleaning glass

Door glass must be clean cold with ammonia-based and non-corrosive degreasers as a diluent. Prevent corrosive substances from coming into contact with the paint on the fireplace as these can cause damage. If glass is hot, before proceeding with cleaning, keep the door open as long as necessary until it cools down. Do not use any material that can scratch or damage the glass.

8.9 Broken glass

The fireplace is equipped with 5 mm thick ceramic glass that is resistant to a thermal shock of 750°C. This glass can break only due to a strong impact or misuse. Do not slam the door or hit the glass. In case of breakage, replace with an original replacement part only.

Contact a Technical Assistance Centre to replace.

8.10 Replacing the remote-control battery

Replace the old battery with a new CR2025 eV battery, taking care not to invert polarity. Then close the remote control and dispose of the used battery in compliance with regulations. The installed battery must be the type specified above. Failure to comply with these instructions may create an explosion hazard.

8.11 Cleaning fans

CAUTION: all cleaning and/or maintenance operations must be performed with the POWER OFF.

The fireplace is equipped with fans (room and fumes) located at the lower rear of the fireplace. Any deposits of dust or ash on fan blades lead to an imbalance which causes noise during operation. Fans must therefore be cleaned at least once annually.

As this operation involves the removal of some fireplace parts, have the fan cleaned by Technical Assistance Centre or qualified personnel only.

8.12 Fireplace inactivity

At the end of the season, perform the following operations:

- Remove all pellets from the tank and from the feed screw.
- Thoroughly clean the brazier, the support brazier, the combustion chamber and the ash drawer.
- Thoroughly clean the smoke exhaust system: contact a professional chimney sweep for this purpose.
- Clean all dust, spider webs, etc. from the area behind the panels of the inner cladding once a year.
- Clean fans thoroughly.
- Disconnect the power cable.
- Leave the fire door ajar to prevent the humidity entering from the smoke duct from oxidizing the internal walls.

8.13 Routine and special maintenance

These operations should be programmed **annually** with a Technical Assistance Centre and are necessary to ensure the maintenance of product efficiency and ensure safe operation.

- Thoroughly clean the combustion chamber and the heat exchanger.
- Smoke motor, dismantling and cleaning of the smoke exhaust duct, new silicone where required.
- Inspection and verification of seals, replacement and silicone application where required.
- Tank, emptying and cleaning.
- Check of electrical and electronic parts.
- Cleaning and check of the tube and pressure gauge.
- Check and replacement, if necessary, of components that are subject to wear: brazier, resistance, ash drawers, etc.



Dasa-Räger
EN ISO 9001 (2000)
IQ-0502-09

Laminox S.r.l.

Zona Industriale Callarella, 261/263 – 62028 SARNANO (MC) Italy

Tel. +39 0733.657.622 – Fax +39 0733.657.494

www.laminox.com

e-mail: export@laminox.com